

Strange



RaceStrange

- Fully machined lightweight aluminum housing & components
- 16", 17", 18", 19", 20", 21", 22" and 23" center to center 4-link widths
- 3/4" thick and internally ribbed faceplate
- Integral wheelie bar mounts
- Housing and 4-link plates are lugged for greater strength
- Pre-loaded spindle bearings with billet spindle nut and pre-load spacer
- Available for full floating or 2-piece axles
- Steel or carbon brake kits

Instruction packet:

- pg. 3 - Kit overview
- pg. 4 - 4-Link plate dimensions
- pg. 5 - Housing dimensions
- pg. 6 - Face plate and end bell stud installation
- pg. 7 - Endbell and mounting brackets assembly
- pg. 8 - Full floating axle assembly
- pg. 9 - Full floating axle parts list
- pg. 10 - 2-Piece axle assembly
- pg. 11 - Brake kit options
- pg. 12 - Brake profile clearance

**8300 North Austin Ave.
Morton Grove, IL
60053**

📞 847-663-1701

📠 847-663-1702

Kit Overview

Full Floating Axle Assembly Options

Wheel to wheel widths	4-Link CTC (Center to Center)	4-link plate	Brakes	Bolt circles	Lug nuts
31.75"	16	Standard	11.50" Steel	4.75	Aluminium
32.75"	16, 17	Reinforced	11" Carbon	5.00	Steel
33.25"	16	No plates Adjustable Shock Height Mount		5.50 <small>Only available for WTW widths 31.75"-40.75"</small>	
33.75"	16, 18				
34.25"	16, 17				
34.75"	16, 17, 18, 19				
35.25"	18				
35.75"	18, 20				
36.25"	18, 19				
36.75"	18, 19, 20, 21				
37.25"	20				
37.75"	20, 22				
38.25"	20, 21				
38.75"	20, 21, 22, 23				
39.25"	22				
39.75"	22				
40.25"	22, 23				
40.75"	22, 23				
41.00"	16				
42.00"	17				
43.00"	18				
44.00"	18, 19				
45.00"	20				
46.00"	20, 21				
47.00"	22				
48.00"	22, 23				

Note: All WTW widths have the option to be shortened by 1/2" by taking material off from the Endbells

Full Floating Axle Wheel Studs

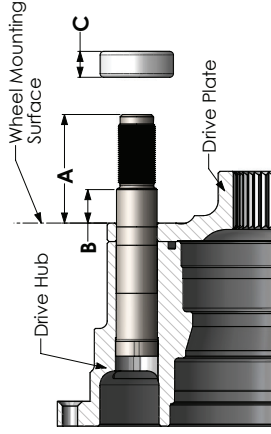

Studs	A	B	C	Lug nuts
F2058BSP	1.90"	0.65"	0.250	steel
F2058BAP	1.90"	0.65"	n/a	aluminium
F2058BLP	2.65"	1.65"	0.4375	steel

⚠ For wheel stud replacement please contact Strange Engineering

Steel & aluminium lug nut torque: 130 ft-lbs

2 Piece Axle Wheel Studs

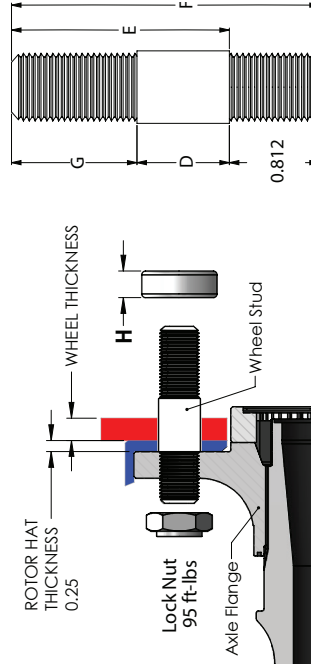

Studs	D	E	F	G	H
A1036	0.775	1.550	2.362	0.775	0.250
A1037	0.875	2.063	2.875	1.188	0.4375
A1037MD	0.875	1.760	2.572	0.885	0.250

⚠ Ensure measurement "D" is able to fully engage into the wheel. The "D" dimension needs to be slightly greater than combined thickness of the brake rotor hat and thickness of the wheel

Lug nut torque: 130 ft-lbs
Wheel Stud Torque: 50 ft-lbs
Lock Nut Torque: 95 ft-lbs

2-Piece axle assembly options

Wheel to wheel widths	4-Link CTC (Center to Center)	4-link plate	Brakes	Bolt circles	Lug nuts	Bearing
31.50"	16	standard	Steel	4.75	Aluminium	Dual row ball
32.50"	16, 17	reinforced	(2 pc. rotor)	5.00	Steel	Spherical misalignment
33.50"	17, 18	no plates	Carbon	Custom B.C		
34.50"	18, 19	Adj Shock Height Mount		Available		
35.50"	19, 20					
36.50"	20, 21					
37.50"	21, 22					
38.50"	22, 23					
39.50"	23					

4-Link plate dimensions

Standard 4 Link Plate

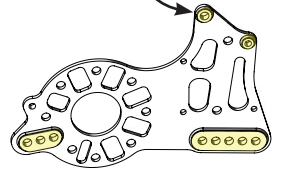
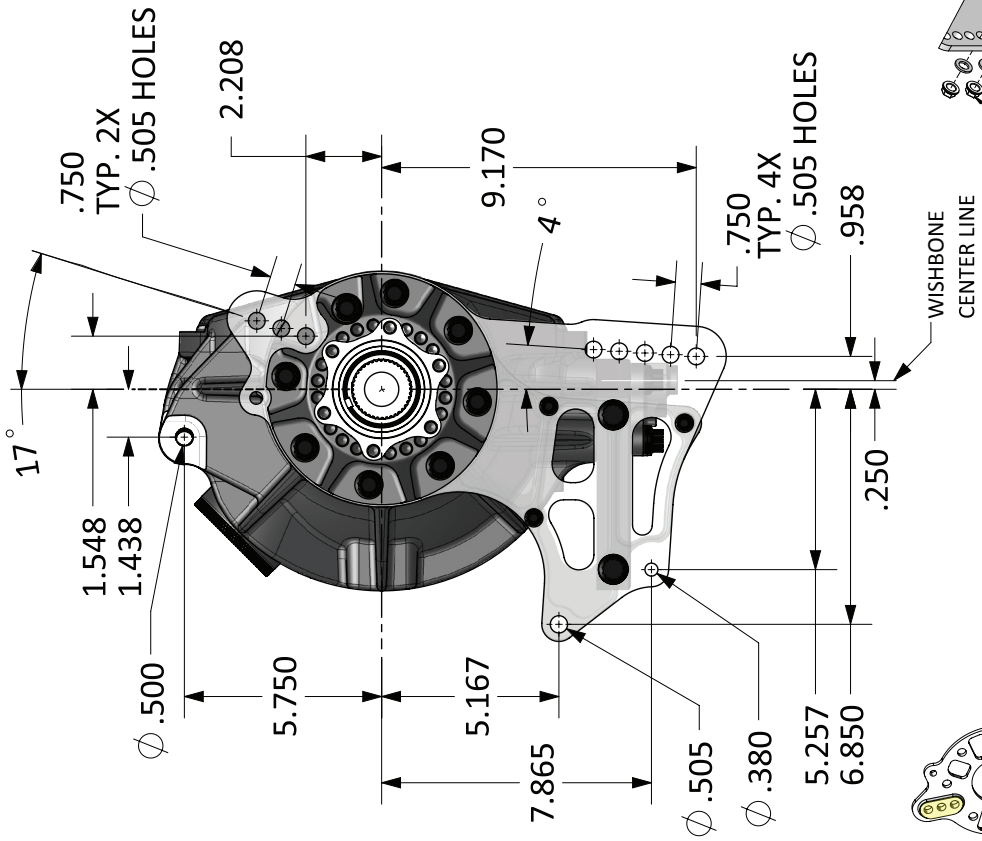

reinforced 4-link plate option

- weld-on bosses double plate thickness at mounting points to increase strength

4-Link Plate with Adjustable shock mount

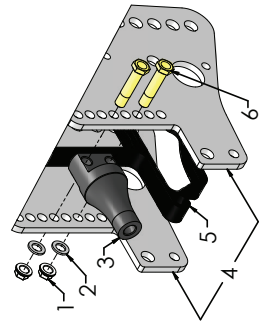
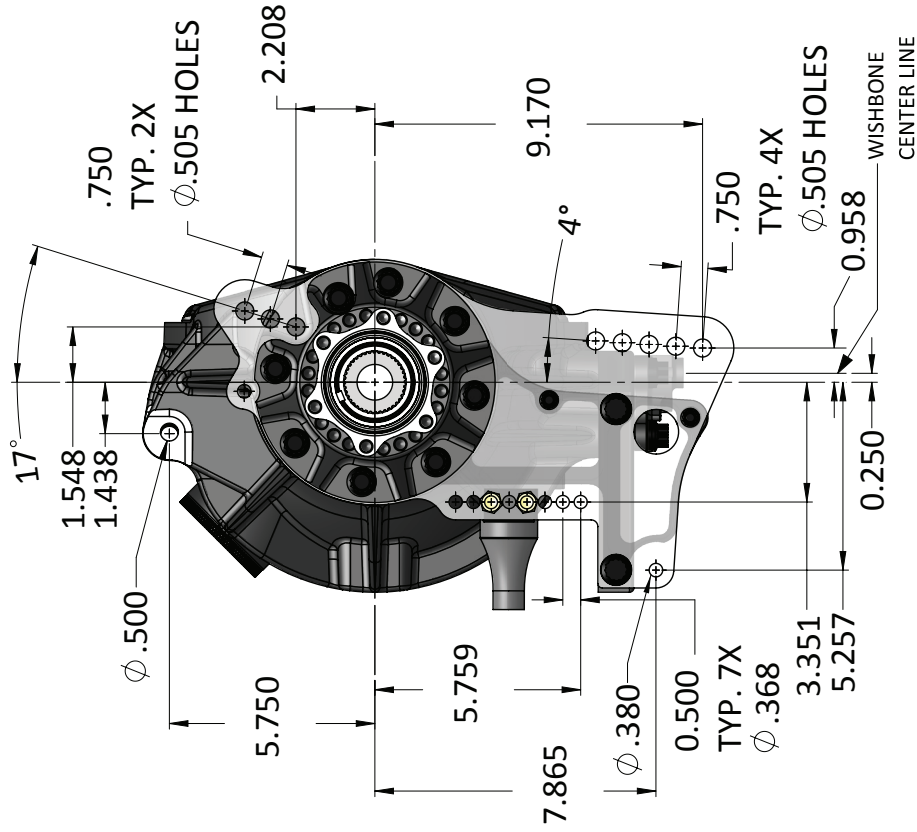

Adjustable shock mount plate parts list

Component	Part #	Qty	Description
1	F1282	4	3/8-24 Jet Nut
2	S3402N	4	3/8 AN Washer
3	H1180V	2	Shock mount 0.750
4	H1180MP1AS	1	HD 4-Link mount plates(4x) -Adj. Shock mount
5	H1180U	2	4-Link spacer plate Adj. Shock mount
6	H1180VA	4	3/8-24 x 1.641" Bolt

Housing dimensions

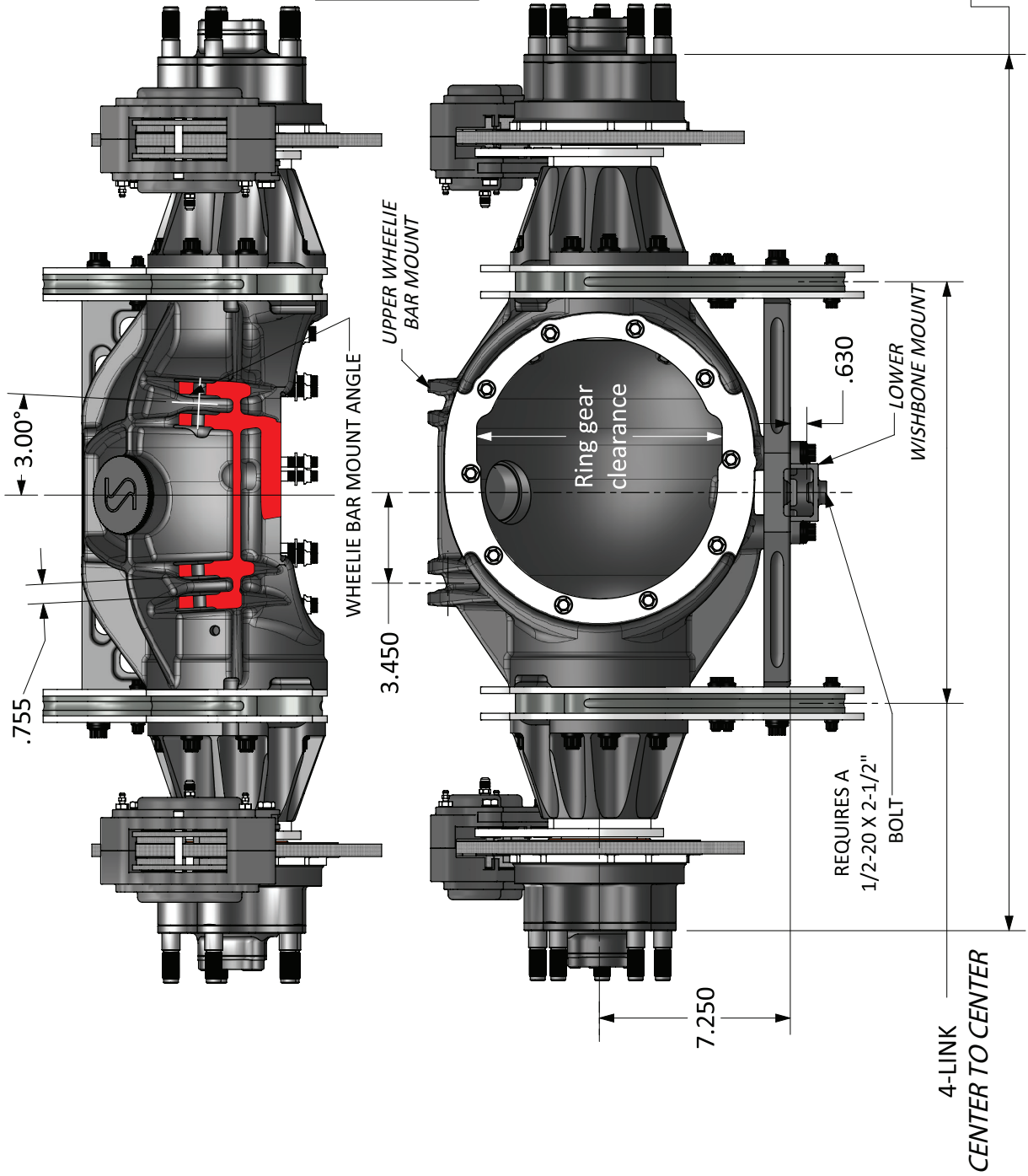

Ring gear clearance revisions	
Date manufactured	Ring gear clearance
2/11 - 10/11	9.195
11/11 - present	9.446

Notes: SAE 85W-140 nonsynthetic gear oil is recommended H1180 housings require 3 quarts of gear oil.

Face plate and endbell stud installation

If the housing end bell studs (1,2) or face plate studs (3,4) have not been pre-installed by Strange Engineering refer to the diagrams below to ensure the proper length studs are installed in corresponding locations. The blue and red colors indicate the variations of stud and bolt lengths.

- red Loctite must be used on the studs (not nuts)

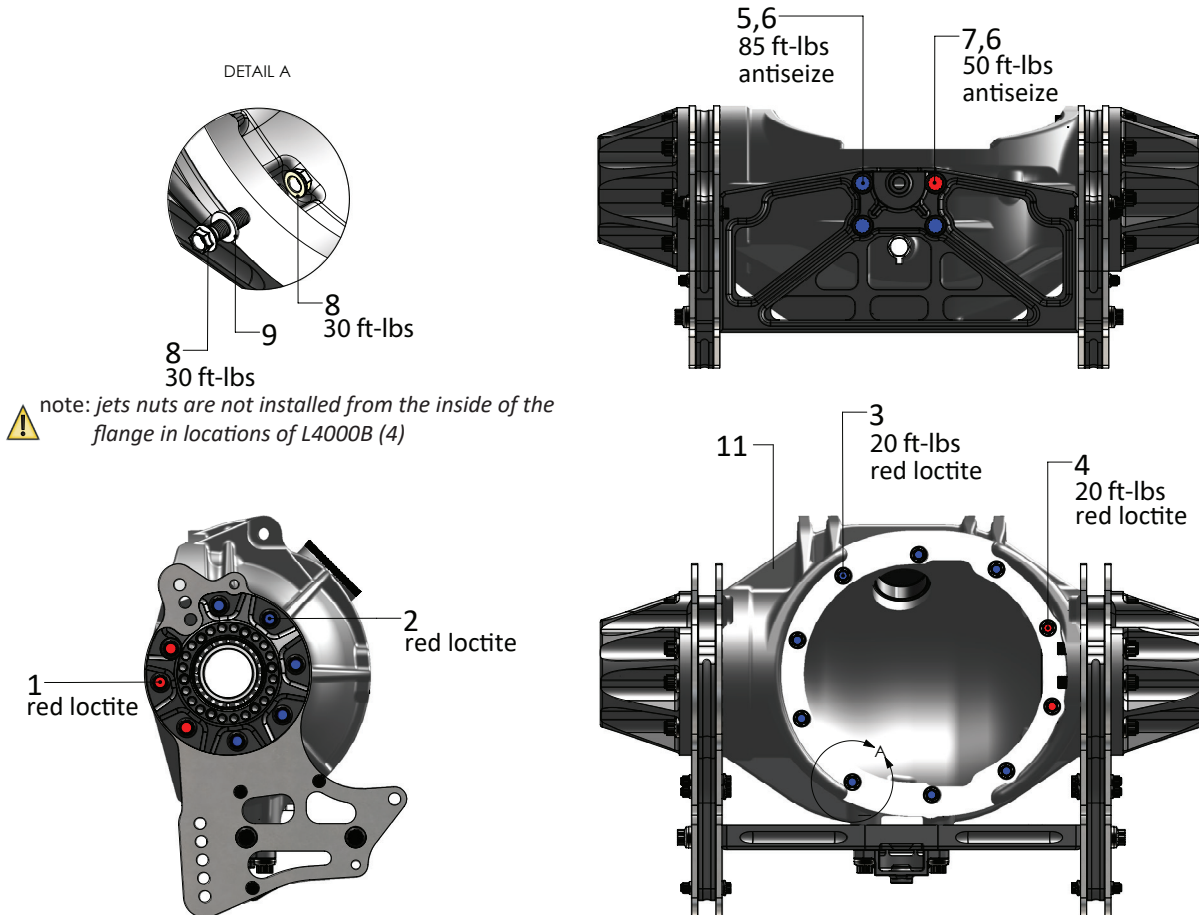

Component	Part #	Quantity	Description
1a	H1180D	3	Housing Tube Stud 2.906" Long
1b	H1180D1	3	Housing Tube Stud 3.781" Long (34.75" WTW)
2a	H1180C	13	Housing Tube Stud 3.312" Long
2b	H1180C1	13	Housing Tube Stud 4.187" Long (34.75" WTW)
3	L4000B1	8	Face Plate Stud 3/8-24 x 2.125"
4	L4000B	2	Face Plate Stud 3/8-24 x 1.50"
5	H1180J	7	1/2-13 x 2.25" 12 Point Screw
6	A1026B	8	1/2" Flat Washer
7	H1180K	1	1/2-13 x 2" 12 Point Screw
8	F1282	18	3/8-24 Jet Nut
9	S3402N	10	3/8" Washer

Endbell and mounting brackets assembly

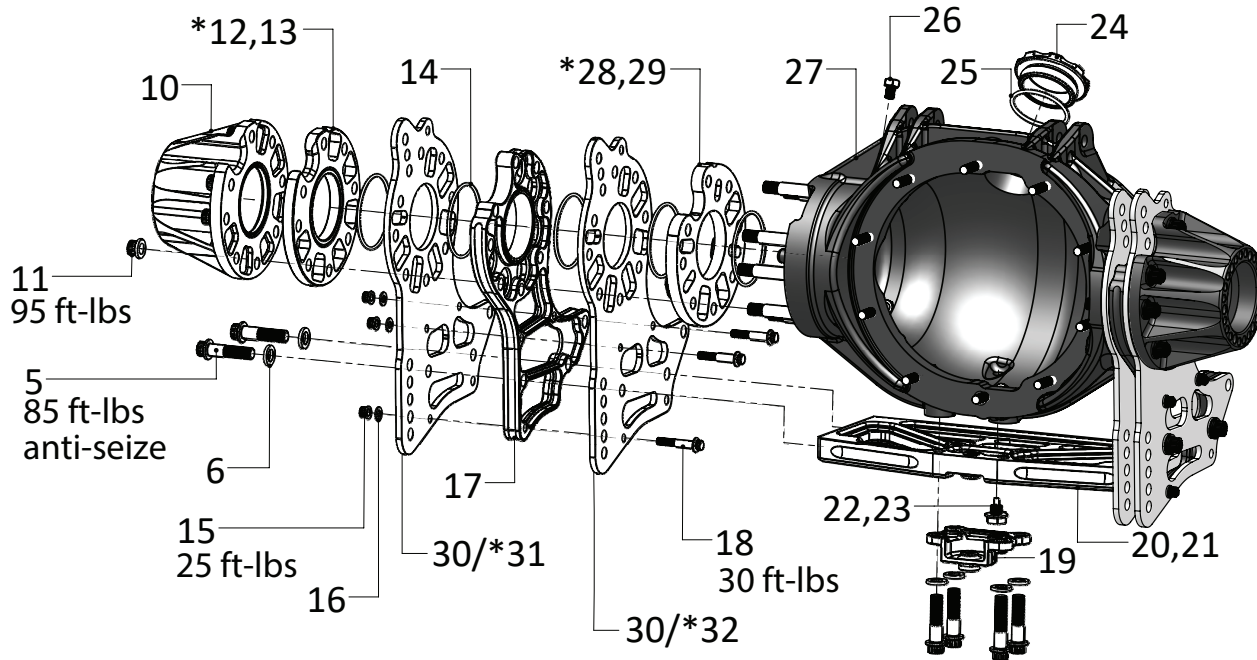

Component	Part #	Quantity	Description	Component	Part #	Quantity	Description
10a	F2094CR3175	1	3.00" End Bell (RH)	22	H1180I	1	Drain Plug
10b	F2094CR	1	3.75" End Bell (RH)	23	H1180IW	1	Drain Plug Gasket
10c	F2094CR3375	1	4.00" End Bell (RH)	24	H1180F	1	Fill Plug
11	H1180Q	16	1/2-20 12 Point Nut	25	H1180H	1	Fill Plug O-Ring
12	H1180SL	1	Endbell Spacer LH	26	H1180P	1	1/8" NPT Breather
13	H1180SR	1	Endbell Spacer RH	27a	H1180A	1	14.75" Modular Housing
14	H1180O	8	-151 O-Ring End Bell	27b	H1180T	1	16.75" Modular Housing
15	H1180M	6	5/16-24 12 Point Nut	28	H1180RR	1	Housing Extension Spacer (RH)
16	S3800W	6	5/16" Washer 1/16" Thick	29	H1180RL	1	Housing Extension Spacer (LH)
17	H1180B	2	Four Link Spacer Plate	30	H1180MP1A	4	4-Link Mount Plate
18	H1180L	6	5/16-24 x 1.75 12 Point Screw	31	H1180MP1HDRO	1	HD 4-Link Mount Plate (RH outside)
19	H1180G	1	Wishbone Retainer	32	H1180MP1HDRI	1	HD 4-Link Mount Plate (RH inside)
20a	H1180E	1	Bottom Brace for 16" CTC	33	H1180MP1HDLO	1	HD 4-Link Mount Plate (LH outside)
20b	H1180E1	1	Bottom Brace for 17" CTC	34	H1180MP1HDLI	1	HD 4-Link Mount Plate (LH inside)
20c	H1180E18	1	Bottom Brace for 18" CTC	35a	F2094CL3175	1	3.00" End Bell (LH)
20d	H1180E19	1	Bottom Brace for 19" CTC	35b	F2094CL	1	3.75" End Bell (LH)
20e	H1180E20	1	Bottom Brace for 20" CTC	35c	F2094CL3375	1	4.00" End Bell (LH)
20f	H1180E21	1	Bottom Brace for 21" CTC				
20g	H1180E22	1	Bottom Brace for 22" CTC				
20h	H1180E23	1	Bottom Brace for 23" CTC				
21	H1180N	1	1/2-20 X 0.650" Big Sert				

Full floating axle assembly

1 Spindle Retainer Nut Installation

Tools (included with all kits)

H1180X - Spindle Retainer Nut Wrench

F2058W - Spindle Nut Wrench for 4-3/4" & 5" B.C.

F2056M - Spindle Nut Wrench for 5-1/2" B.C.

1. Press the spindle (54) into the endbell and align the threaded holes. Then slide the caliper bracket (52) on.
2. Align the threaded holes in the endbell with the holes in the caliper bracket and spindle flange.
3. Install the six flat head screws (51) and torque to 40 ft-lbs.
4. The spindle retainer nut (56) is installed using the provided H1180X wrench. Apply antiseize on the threads of the spindle retainer nut.
5. Torque spindle retainer nut to 150 ft-lbs and align two opposing holes in the retainer nut to mate with the threaded holes in the housing.
6. Apply loctite to a set screw (55) and hand tighten to secure assembly.

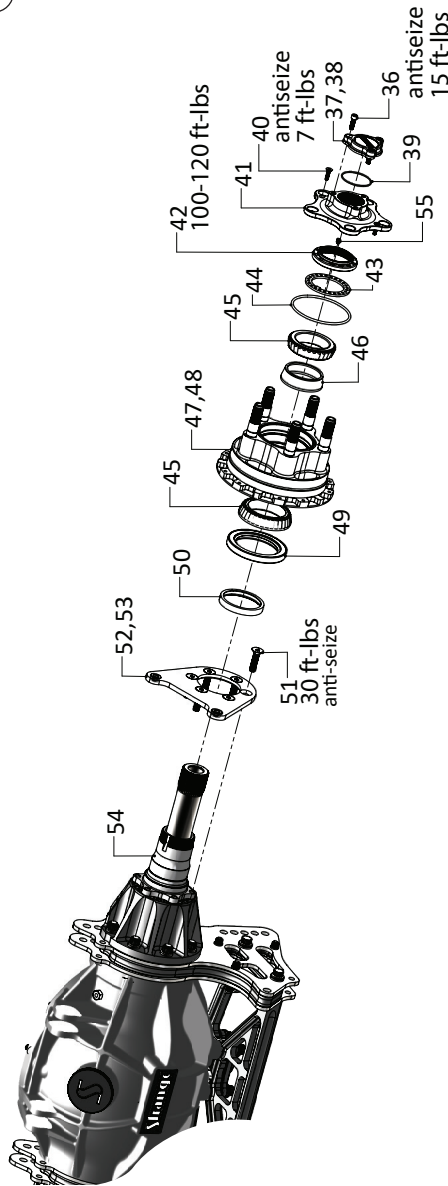

! note: pack the bearings (44) with grease

2 Spindle Nut Installation

Tools (included with all kits)

H1180X - Spindle Retainer Nut Wrench

F2058W - Spindle Nut Wrench for 4-3/4" & 5" B.C.

F2056M - Spindle Nut Wrench for 5-1/2" B.C.

1. Slide the spindle nut retainer (43) onto the spindle ensuring the notches on the retainer and slots on the spindle are oriented properly.
2. Install the spindle nut (42) using the provided F2058W/F2056M wrench. Spindle nuts are torqued to 100-120 ft-lbs.
3. Ensure to align two opposite holes on the spindle nut and retainer for installation of set screws.
4. Thread the set screws opposite one another into the spindle nut. Ensure screws engage into spindle nut retainer.
5. Rotate hub several times to ensure everything is seated.

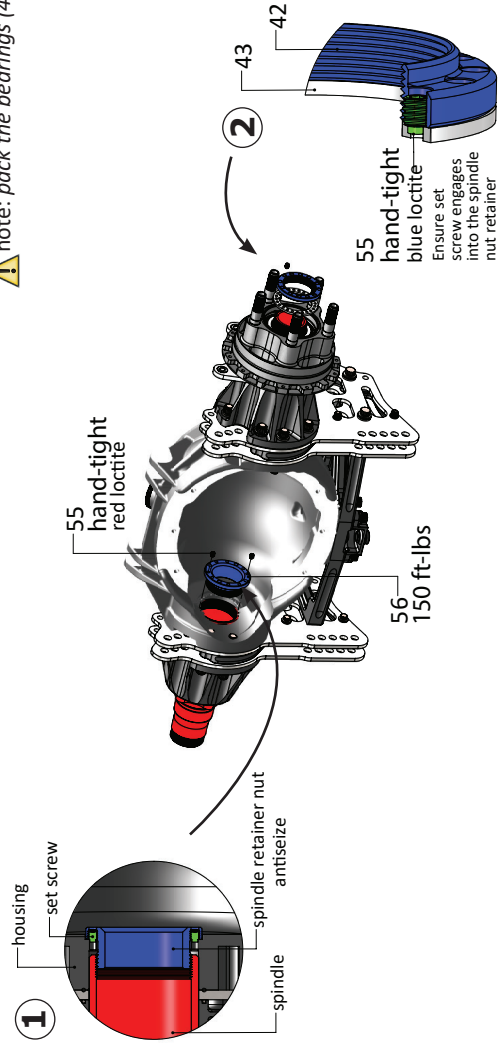

Full floating axle assembly

Component	Part #	Quantity	Description	
36	A1050D	6	1/4-28 x 3/4 SHCS	
37	A1RS	2	Race Decal	
38	F2054B	2	40 Spline Floater Cap	
39	F2200B	2	Drive Cap O-Ring #032	
40	F2200C	4	10-24 x 3/4" FHSCS	
41a	F2060A	2	4.75" B.C. Scalped Driveplate	
41b	F2058A	2	5.00" B.C. Scalped Driveplate	
41c	F2056A	2	5.50" B.C. Scalped Driveplate	
42a	F2058C	2	4.75" & 5.00" B.C. Spindle Nut	
42b	F2056C	2	5.50" B.C. Spindle Nut	
43a	F2058D	2	4.75" & 5.00" B.C. Spindle Nut Retainer	
43b	F2056D	2	5.50" B.C. Spindle Nut Retainer	
44a	F1209C	2	4.75" & 5.00" B.C. Hub O-Ring	
44b	F1277	2	5.50" B.C. Hub O-Ring	
45a	F1270	see note	4.75" & 5.00" B.C. Outer Bearing Cone L507949	
45b	F2056I	see note	5.50" B.C. Inner & Outer Bearing Cone L610549	
46a	F2058E	2	4.75" & 5.00" B.C. Preload Spacer	
46b	F2056E	2	5.50" B.C. Preload Spacer	
47a	F2060H	2	4.75" B.C. Floater Drive Hub	
47b	F2058H	2	5.00" B.C. Floater Drive Hub	
47c	F2056P	2	5.50" B.C. Floater Drive Hub	
48a	F1271	see note	4.75" & 5.00" B.C. Outer Bearing Cup L507910	
48b	F2056J	see note	5.50" B.C. Inner & Outer Bearing Cup L610510	
49	F2056K	2	Hub Seal SKF 28745	
50	F2056B	2	Spindle Ring	
51	F2058G	12	3/8-16 x 1-1/2 FHSCS	
52a	F2056O	2	Caliper Mounting Bracket (<i>Steel Brakes</i>)	
52b	F2056F	2	Caliper Mounting Bracket (<i>Carbon Brakes</i>)	
53	B1301E	4	3/8-24 Press Nut	
54a	F2094A3175	2	9.25" Spindle	4.75" & 5" B.C.
54b	F2094A3275	2	9.75" Spindle	
54c	F2094A	2	10.00" Spindle	
54d	F2094A3375	2	10.25" Spindle	
54e	F2094A3425	2	10.50" Spindle	
54f	F2094A3475	2	10.75" Spindle	
54g	F2092A3175	2	9-11/32" Spindle	5.5" B.C.
54h	F2092A3275	2	9-27/32" Spindle	
54i	F2092A3325	2	10-3/32" Spindle	
54j	F2092A3375	2	10-11/32" Spindle	
54k	F2092A3425	2	10-19/32" Spindle	
54l	F2092A3475	2	10-27/32" Spindle	
55	F2056L	8	1/4-20 x 5/16" Dog Pt. Set Screw	
56	F2094B	2	Spindle Retainer	

Note: 5.50" B.C. Kits include a quantity of 4 F2056I & F2056J
4.75" & 5.00" B.C. Kits include a quantity of 2 F2056I, F2056J, F1270 & F1271

2-Piece axle assembly

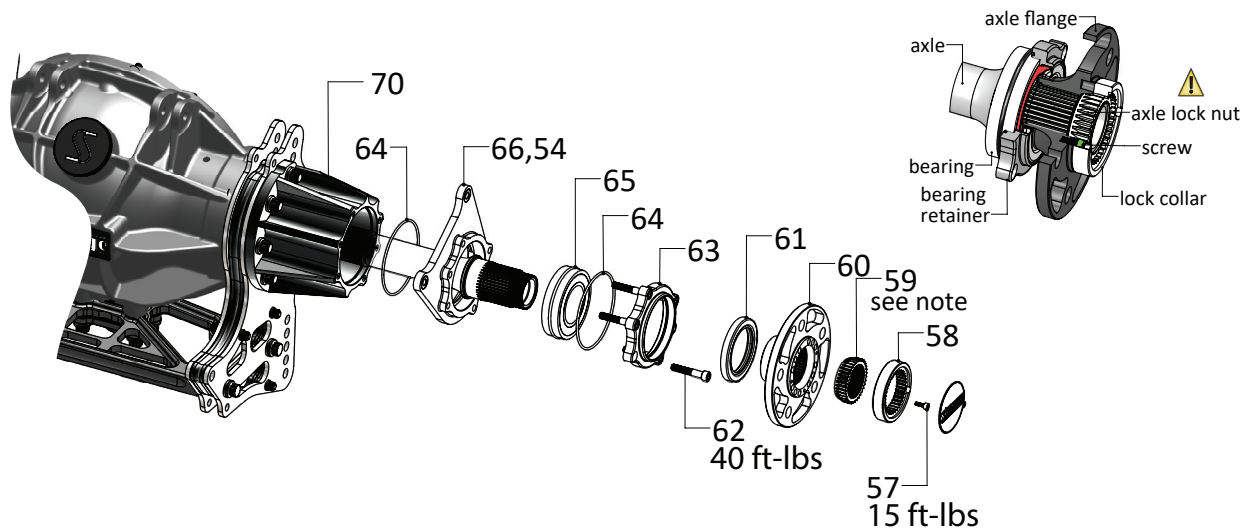

⚠ Axle lock nut (59) should be torqued to **250 ft-lbs**. Then add additional torque until holes in the lock collar match either pair of threaded holes in the flange. Check and retorque axle lock nut periodically!

Tools:

WJ11 - Axle lock nut tool (included with kit)

WJ13 - Axle holder (optional)

If the optional WJ13 tool is not being used install the axle in the spool and then torque the axle nut.

Component	Part #	Quantity	Description
57	WJ10	4	10-32 x 1/2" SHCS
58	WJ08	2	Lock Collar
59	WJ04	2	Axle Lock Nut
60a	WJ024	1	4.75" B.C. Axle Flange Passenger Side
60b	WJ030	1	5.00" B.C. Axle Flange Passenger Side
61	WJ01	2	Seal National #411394
62	WJ100D	12	5/16-18 x 1-3/4 SHCS
63	WJ100AR	1	Passenger Side Bearing Retainer
64	WJ036	4	O-Ring #153
65a	WJ00	2	Spherical Misalignment Bearing
65b	WJBB	2	Ball Bearing
66a	WJ102BR	1	Passenger Side Caliper Mounting Bracket (Steel Brakes)
66b	WJ100BR	1	Passenger Side Caliper Mounting Bracket (Carbon Brakes)
67a	WJ102BL	1	Driver Side Caliper Mounting Bracket (Steel Brakes)
67b	WJ100BR	1	Driver Side Caliper Mounting Bracket (Carbon Brakes)
68	WJ100AL	1	Driver Side Bearing Retainer
69a	WJ023	1	4.75" B.C. Axle Flange Driver Side
69b	WJ029	1	5.00" B.C. Axle Flange Driver Side
70a	WJ100CR	1	5.00" 2pc. Axle End Bell Passenger Side
70b	WJ102CR	1	4.50" 2pc. Axle End Bell Passenger Side
71a	WJ100CL	1	5.00" 2pc. Axle End Bell Driver Side
71b	WJ102CL	1	4.50" 2pc. Axle End Bell Driver Side

Brake kit options

Full Floating Axle Steel & Carbon Brake Assembly

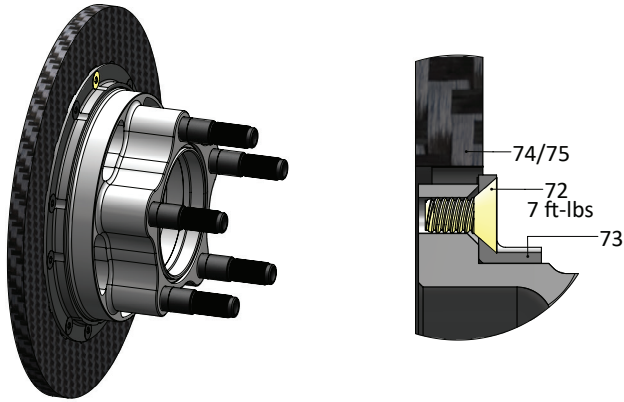

Brake Caliper

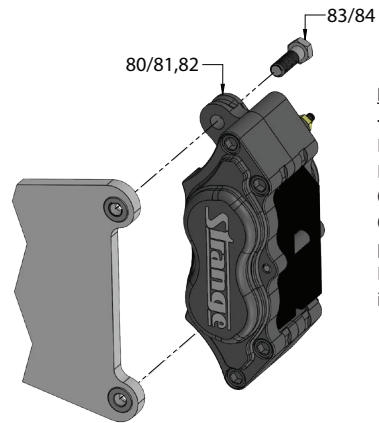

Notes:
 - Consult B1950 B1955 Strange Four Piston Directional Caliper and Ultra Caliper (Black Calipers) B5044, B5045, B5046, B5040, B5042 instructions

2-Piece Axle Steel & Carbon Brake Assembly

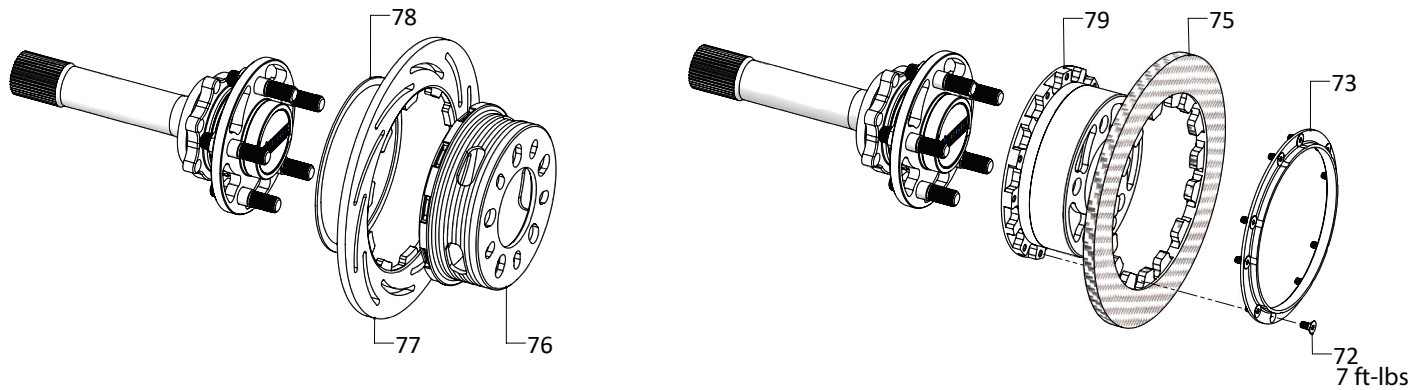

Component	Part #	Quantity	Description
72	C1700D	20	1/4-20 x 1/2" FHSCS
73	C1700H	2	Retainer Ring
74a	F2056NR	1	11.5" Rear Rotor RH
74b	F2056NL	1	11.5" Rear Rotor LH
75	C1790	2	11" Carbon Rotor
76	B2794B	2	Rotor Adapter
77	B2794A	2	Brake Rotor
78	B2794D	2	Spirolock
79a	C1700B	1	4.75 B.C. Carbon Adapter RH
79b	C1700C	1	4.75 B.C. Carbon Adapter LH
79c	C1700F	1	5.00 B.C. Carbon Adapter RH
79d	C1700G	1	5.00 B.C. Carbon Adapter LH
80	B1955	1	Four Piston Caliper w/ Hard Metallic Pads
81	B5040	2	Four Piston Carbon Caliper
82	L4050HS	4	Carbon Soft Pad
83	B5000Y	4	3/8-24 x 1.125" HHSC (included in B1855 kit)
84	B5000X	4	3/8-24 x 1.27" Bolt

