

C-CLIP ELIMINATOR KIT WITH TAPERED BEARING

APPLICATIONS & KIT

- 05-14 OEM Mustang GT & 05-12 GT500 Disc brake with 11.8" dia rotor
 - A1098- Factory axles
 - A1099-Strange race axle 1.773" H bearing journal diameter and 0.985" B bearing shoulder
 - A1099ST-Strange axles 1.563" H bearing journal diameter and 1.187" B bearing shoulder
- 13-14 GT500 Disk brake with 13.8" dia rotor
 - A1098GT5- Stock axles with factory 05' Mustang Hsg ends
 - A1099GT5- Strange race axles with OEM 05' Mustang Hsg ends
 - A1099STGT5- Strange axles 1.563" H Dim. with factory 05' Mustang Hsg ends

Kit Contents			
ITEM#	PART#	QTY	DESCRIPTION
1	A1098I	2	Reluctor ring (optional)
2a	A1098D	2	Bearing sleeve (A1098 only)
2b	B1105F	2	Bearing spacer/reluctor ring adapter (A1099 only)
2c	B1105H	2	Bearing sleeve/reluctor ring adapter (A1099ST only)
3	A1098C	2	Safety hub outer half
4	A1098F	2	Axle seal National #473204
5	A1100E	2	Timken U497 tapered axle bearing
6a	A1098E	2	Wedding ring (A1098 only)
6b	A2000C	2	Wedding ring (A1099 only)
6c	A1021B	2	Wedding ring (A1099ST only)
7	A1098G	2	Caliper mount o-ring
8	A1098A	1	Driver side caliper mount
8a	A1098AG	1	13-14 LH Mustang brake bracket (A1098GT5, A1099GT5, A1099STGT5 only)
8b	A1098BG	1	13-14 RH Mustang brake bracket (A1098GT5, A1099GT5, A1099STGT5 only)
9	A1098H	8	M10-1.5 x 40mm HHCS
10	A1026B	4	1/2" Flat washer
11	A1098B	1	Passenger side caliper mount

Housing Preparation

Note: The bearing spacer/reluctor ring adapter will move all axle "B" dimensions to 1.486". (figure 1)

1. Remove wheel and tire, brake caliper and rotor. The caliper does not have to be completely disconnected. Securely hang it on the side. Do not allow it to hang by the brake hose.
2. Remove axle from the housing (axle c-clip must be removed first).
3. Unbolt the stock caliper bracket from the housing.
4. Remove the stock bearing and seal from the housing snouts. This is best accomplished using a slide hammer.
5. Refer to figure 2 and shorten the housing snout leaving the register for the backing plate only.

Note: Remove any rust, dirt, burrs or grease from the face of the modified housing.

Axle Preparation

Note: Wheel studs must be installed prior to installing optional reluctor rings (05-up Mustangs must reuse factory ring)

6. If applicable press the reluctor ring (1) on the on the adapter (2). Ensure correct orientation as shown.
7. Press the reluctor ring assembly on the axle against the shoulder of the axle.
8. Press the safety hub assembly (3,4,5) onto the axle. The side with the axle seal must face outboard.
 - Note:** Press only on the inner race of the bearing and ensure bearing seats fully against the spacer (2).
9. Press the wedding ring (6) on the axle until it seats flush against the bearing.
10. Position the o-ring (7) over the outside diameter of the axle bearing and flush up against the safety hub.
11. Press the caliper mount (8) over the axle bearing (5) with the stepped side facing inboard. Ensure to line up the ABS sensor holes in the bracket and safety hub outer half.

Axle Installation

12. Apply a bead of RTV silicone between the surfaces of the housing end and inboard side of the caliper mount. (figure 3)
13. Coat the splines of the axle and ends with white lead compound or grease. This will help determine axle spline engagement to check for differential contact. The button on the end of stock axles must be completely cut off.
14. Slide the axle assembly into the housing ensuring the caliper is oriented towards the front of the car.

Note: Due to a variety of differentials and gear ratios, ensure the axle shafts do not contact the differential cross pin. The axle must be cut if it makes any contact.

15. Install the four safety hub bolts (9) and torque to 35 ft-lbs.
16. Install the factory ABS sensor and retaining bolt if applicable.
17. Reinstall factory brake components and wheel and tire.

FIGURE # 1: Axle B-dimension

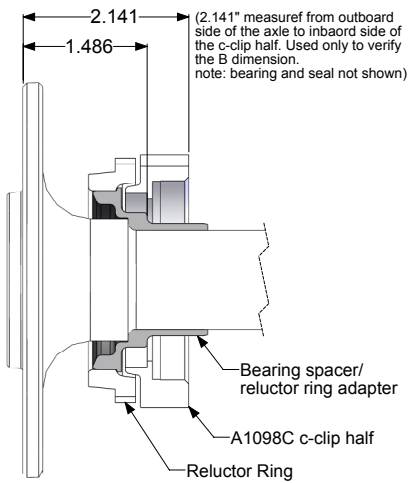

FIGURE # 2: Housing modification

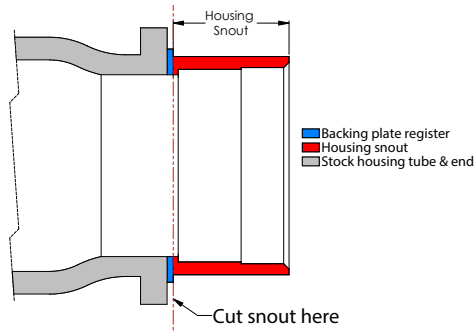

FIGURE # 3: Caliper mount RTV

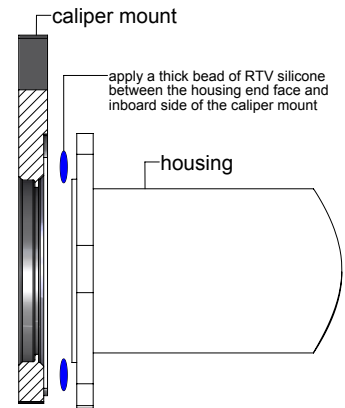
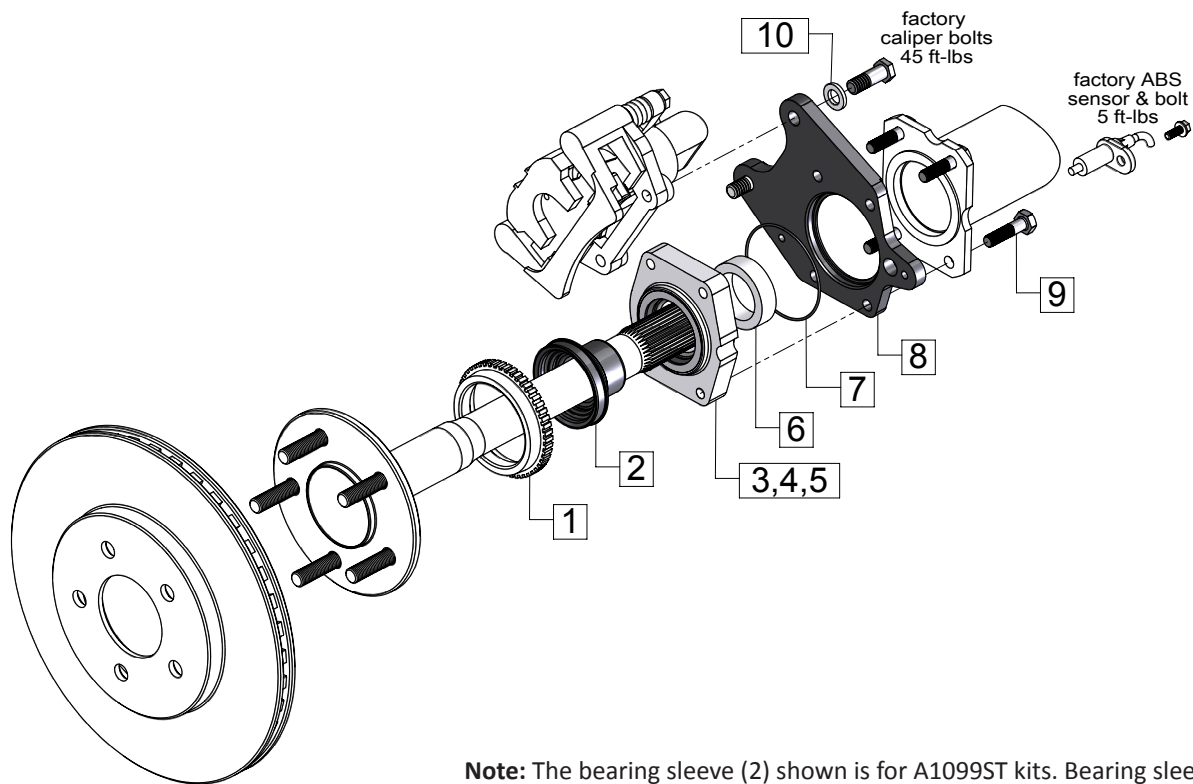

FIGURE # 4: Exploded assembly



Note: The bearing sleeve (2) shown is for A1099ST kits. Bearing sleeves are not identical for all kits, however, the assembly remains the same.