

Installation
Instructions

Kit # B4158WC
Strange Pro Race Steel Front Brake Kit

Applications:
66-69 Mopar "B-Body"
Drum Brake Spindles

BEFORE YOU BEGIN INSTALLATION:

Consult Directional Caliper Kit installation instructions to mount the brake caliper.
Consult pg. 112 of Strange Engineering catalog for available brake lines.
Clean and inspect spindle for damage (spun wheel bearings, stripped threads, etc.).
A bearing packer is recommended but not required for this installation.
Remove the stock drum, hub and backing plate assembly from the spindle.
Inspect upper and lower ball joints for excessive play and replace as needed.
Read these instructions thoroughly and save for future reference.
If after reading these installation instructions, you have any questions or comments, please do not hesitate to call us.

Note: If using WELD "V" series wheels, a modification to either the hub or the wheel must be preformed for the wheel to fit.

Kit Contents

Item #	Part #	Qty.	Description
1	B4154E	2	Aluminum Hub Cap
2	S3520F	2	Hub Cap Buna O-ring
3	B1324E	2	Outer Hub Bearing Cone (<i>Timken LM11949</i>)
4	B4158F	2	Front Hub "CB" 4.5" Bolt Circle
5	B1320H	2	Inner Hub Bearing Cup (<i>Timken LM67010 pre-installed in B4158F</i>)
6	B1324D	2	Outer Hub Bearing Cup (<i>Timken LM11910 pre-installed in B4158F</i>)
7	B2796	1	Heavy Duty Tapered 11.25" OD Slotted Rotor (<i>Driver Side</i>)
8	A1028B	10	1/2" I.D. Wheel Stud Washer
9	A1028A	10	1/2"-20 x 2.5" Wheel Stud
10	B1320J	2	Inner Hub Bearing Cone (<i>Timken LM67048</i>)
11	B1320N	2	Hub seal (National #40494S)
12	B1386C	2	7/16"-20 x 2.00" Hex Head bolt
13	B4158A	2	5/8"-18 x 2.75" Hex Head bolt
14	B1850	1	Strange Four Piston Directional Caliper Kit
15	B4158GL	1	Caliper Mounting Bracket (<i>Driver Side</i>)
16	B1301E	4	3/8-24 Press Nut
17	B1380B	8	5/8"x.025 Shim
18	B1380C	8	1/2"x.025 Shim
19	B4158B	2	5/8"-18 Nyloc Lock Nut
20	B1346C	2	7/16"-20 Lock Nut
21	B4158GR	1	Caliper Mounting Bracket (<i>Passenger Side</i>)
22	B2795	1	Heavy Duty Tapered 11.25" OD Slotted Rotor (<i>Passenger Side</i>)

IMPORTANT NOTES:

- B2795/B2796 Steel brake rotor minimal thickness is **0.312"**
- B5010 Semi-metallic brake pad minimal thickness is **0.200"**
- Calipers are tapped to 1/8"-27 NPT and supplied with -3AN fittings.
- Strange Engineering brake kits are designed for **drag racing only**.
- To determine the change in wheel offset please use the figure on the side as a reference. Measure the OEM distance from the **caliper bracket mounting surface** to the **wheel mounting surface**. Compare measured distance to the provided 3.125" distance and the difference will give the change in wheel offset. Please note the given distance does not include any additional shims.

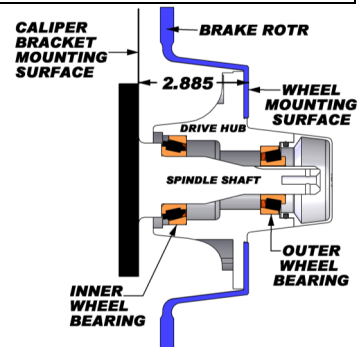

WARNING – RACING IS HAZARDOUS · STRANGE BRAKES ARE FOR LEGAL DRAG RACING ONLY

Disclaimer of Warranty – Purchasers using Strange Engineering racing components and equipment any and all inventory services, purchasers acknowledge that due to differing conditions and circumstances under which all equipment and parts are installed and used, purchasers are not relying on Strange Engineering Co. skill or judgment to select or furnish the proper part or equipment. Purchasers expressly affirm they are relying upon their own skill or judgment to select and purchase suitable goods. Strange Engineering Co. makes no warranties whatsoever, expressed or implied, oral or written, to purchasers. There is no warranty of merchantability made to purchasers. Strange Engineering Co., further excludes any implied warranty of fitness with respect to racing and equipment, any and all inventory and service.

Installation Instructions

Kit # B4158WC

Figure 1:
Directional
Caliper
& Rotors

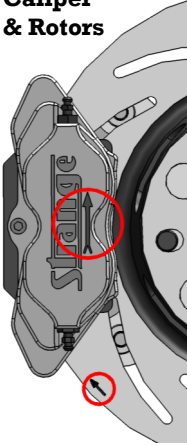

1. Raise and support front of vehicle on a level surface using suitable equipment.
2. Remove the factory steering arm retaining bolt found at the front of the spindle.
3. Temporarily attach the caliper mounting bracket (15) to the spindle using the bolts (12, 13) and nuts (19,20) in their respective holes on the spindle body. Do not use any shims between the caliper bracket and spindle body at this point.
4. Using one 1/2" washer (8) under the head of each wheel stud (9), install studs in the hub (4).
Torque the wheel studs (9) to 65 ft-lbs and use blue Loctite.
5. Pack the inboard and outboard wheel bearings (3,10) with NLGI 1 wheel bearing grease.
▪ **Note:** A bearing packer is recommended for this procedure. If one is not available work as much grease as possible into the cage and around the rollers of the bearings.
6. Wipe a thin layer of wheel bearing grease on the bearing surface of the inner and outer cups (5,6) and then place inner bearing cone (10) into the front hub.
7. Press the hub seal (11) into the inboard side of the hub.
8. Slide the hub assembly onto the spindle then slide the outer bearing cone (3) into the hub.
9. Install the spindle nut washer and hand tighten the spindle nut.
10. Slide the brake rotor over the wheel studs flush to the face of the hub. Temporarily install lug nuts hand tight against the rotor to keep the rotor seated flat against the hub.
11. Consult Directional Caliper Kit installation instructions to mount the caliper onto the caliper mounting bracket.
▪ **Note:** The arrow on the caliper must face the normal rotation of the rotor/wheel (figure 1). The caliper must also be centered with the rotor. If the caliper needs to be shifted outboard then remove the hub assembly and caliper mounting bracket to install shims (17,18) between the caliper mounting bracket and spindle body. Each shim will shift the caliper outboard by 0.025". Torque top bolt (12) to 50 ft-lbs and bottom bolt (13) to 95 ft-lbs.
12. Install wheel, tire and lug nuts.
13. While rotating the wheel, torque the spindle nut to 20 ft-lbs
14. Back the spindle nut off until the wheel spins freely and there is no end play, install the cotter pin.
15. Install the hub cap (1) with the o-ring (2).
16. Connect the hydraulic lines to the calipers. Calipers are tapped to 1/8"-27 NPT and supplied with -3AN fittings. Use proper adapters to connect or use new -3AN braided steel line (teflon lined). Bleed the calipers with DOT 4 or DOT 5.1 brake fluid **ONLY**.
17. A proper break in procedure is required to avoid brake fade and uneven rotor deposits from the pads. It consists of 8-10 brake applications increasing in harshness while allowing the brakes to cool slightly in between; do not keep the brakes applied between stops. After the last stop the brakes should be allowed to cool completely.

Figure 2: Driver Side Brake Kit Assembly

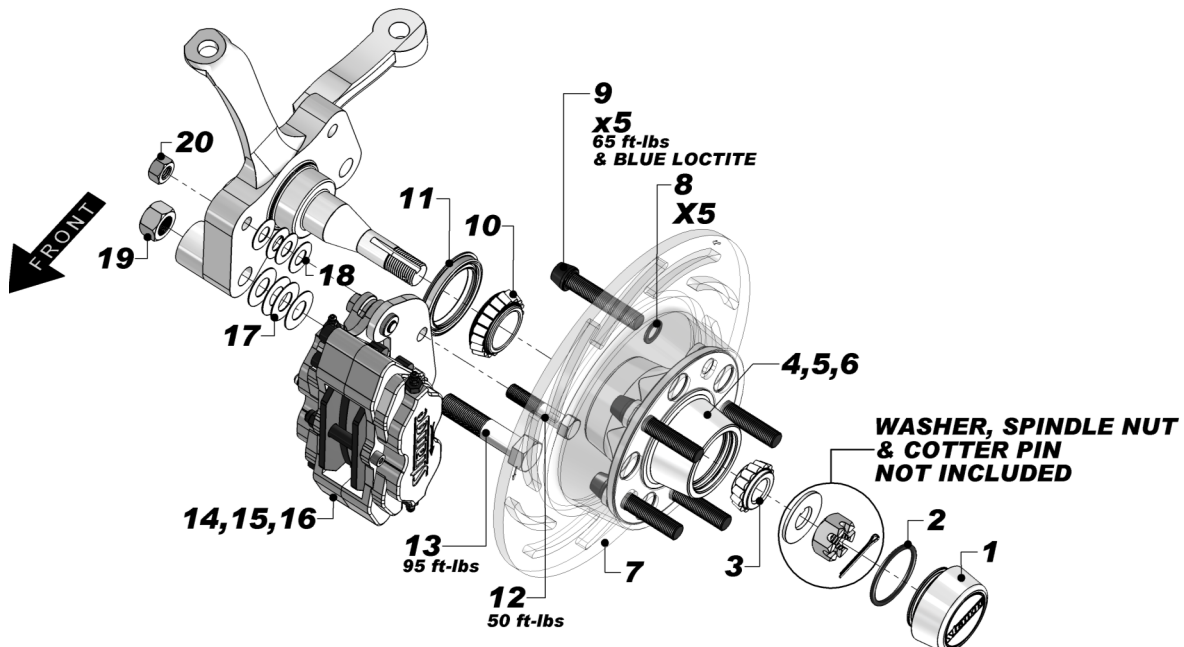

Note: Consult Directional Caliper Kit installation instructions to mount the caliper and install the brake pads.