

Strange

Engineering

8300 North Austin Avenue · Morton Grove IL 60053 · 847-663-1701 · Fax 847-663-1702 ·

Installation instructions for B4148WC heavy duty (4-piston) front brake kit for 2005-Up Ford Mustangs.

Before you begin installation: Strange Engineering brake kits are designed for **DRAG RACING ONLY!** Read these instructions thoroughly and save for future reference. If after reading these installation instructions, you have any questions or comments, please do not hesitate to call us.

KIT CONTENTS

<u>Item#</u>	<u>Part#</u>	<u>Qty.</u>	<u>Description</u>
1	B1301E	4	3/8-24 Press nut (installed in B4148AR & B4148AL)
2	B2792	1	Right hand HD/MD rotor
3	B2793	1	Left hand HD/MD rotor
4	B4148AR	1	Right hand caliper bracket
5	B4148AL	1	Left hand caliper bracket
6	B4148B	2	Wheel Spacer
7	B4148C	4	3/8-16 x 1" FHSCS tapered bolt
8	B5002	1	R.H. 4-piston aluminum caliper
9	B5004	1	L.H. 4-piston aluminum caliper
10	B5010	4	Soft 4-piston caliper pad
11	B1301J	4	3/8" I.D. x 1/16" thick caliper washer
12	B1301H	16	3/8" I.D. x 0.025" thick caliper shim
13	B5000Y	4	3/8-24 x 1.125" Caliper bolt

<u>Item #</u>	<u>Torque Spec (ft-lbs.)</u>
7	35
13	35

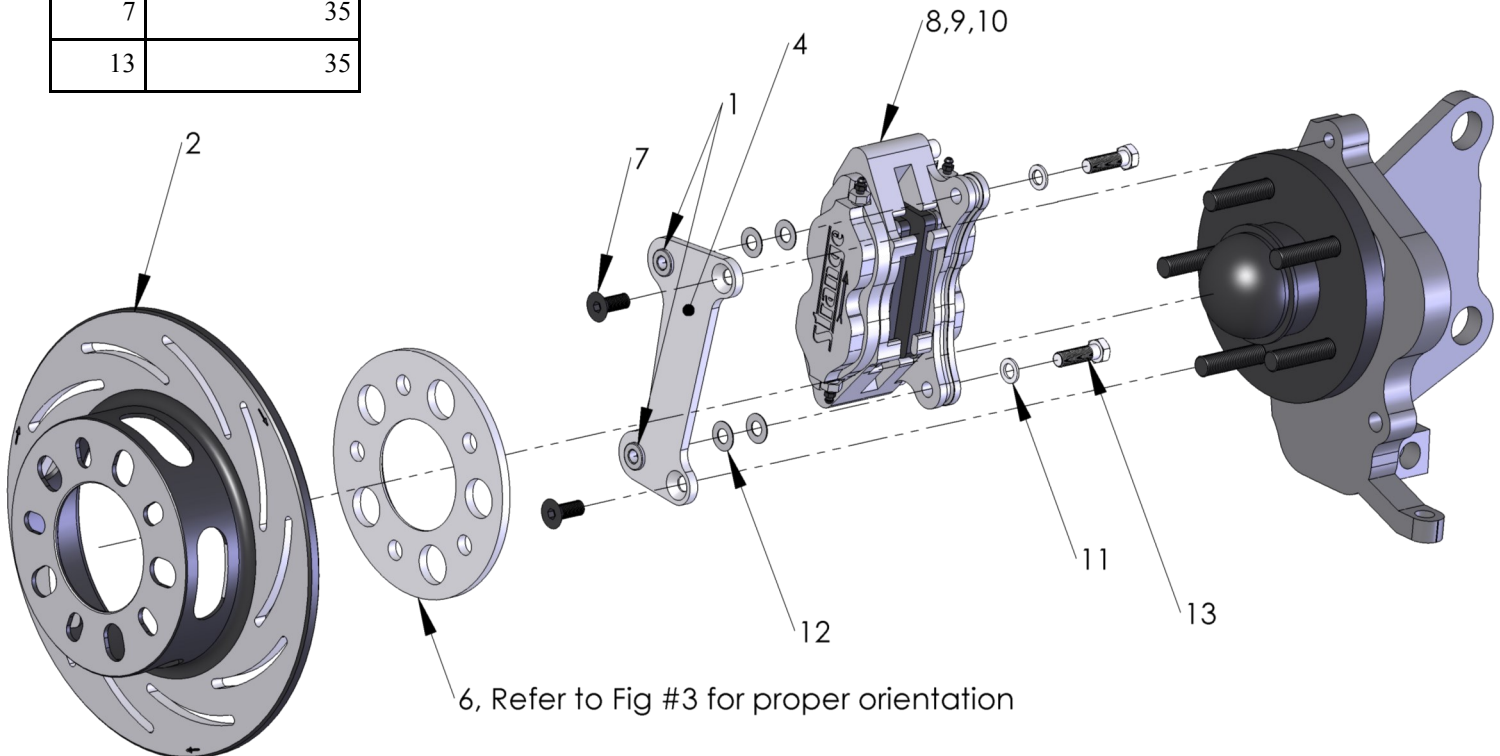
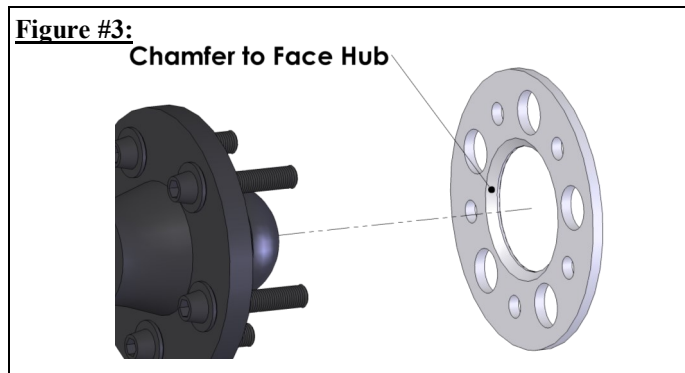

Figure #1: Passenger side shown

(turn over)

Installation Instructions:

- 1.) Raise and support front of vehicle on a level surface using suitable equipment.
 - 2.) Remove wheel, stock disc, brake line, caliper assembly and dust shield from spindle.
 - 4.) Remove stock caliper mounting ears as shown (Fig 2).
 - 5.) Drill holes to 5/16" and tap stock dust shield holes (Fig 2) to 3/8"-16.
 - 3.) Mount caliper bracket (4,5) with the press nuts (1) facing outboard using one 3/8-16 x 1" FHSCS caliper bracket bolt (7) in each of the stock bolt locations. Torque to 35 ft. lbs.
 - 4.) Slide the wheel spacer over the wheel studs flush to the face of the hub.
- Note:* Wheel spacer to be mounted with chamfer facing inboard direction (See Figure 3).



- 6.) Attach caliper (8,9) with the arrow pointing in the direction of normal rotation (Figure 4) using 3/8"-24 caliper bolts (13) and 3/8" I.D. flat washers (11). Use two 3/8" I.D. caliper shims (12) per bolt between caliper & bracket (4,5) to center the caliper over the rotor, making sure pads contact the rotor evenly. Use any remaining shims under the head of the 3/8" Dia. Caliper bolt to prevent the bolt from contacting the rotor. Torque caliper mounting bolts (13) to 35 ft.-lbs.
- 7.) Connect the hydraulic lines to the calipers. Calipers are tapped to 1/8"-27 NPT and supplied with -3AN fittings. Use proper adapters to connect them to existing lines or use new -3AN braided steel line (teflon lined). Bleed the calipers with DOT 4 or DOT 5.1 brake fluid **ONLY**.
- 8.) Replace wheel and torque lug nuts to factory specification.
Note: **This kit moves the wheel .06" outboard.**
- 9.) A proper break in procedure is required to avoid brake fade and uneven rotor deposits from the pads. It consists of 8-10 brake applications increasing in harshness while allowing the brakes to cool slightly in between; do not keep the brakes applied between stops. After the last stop the brakes should be allowed to cool completely.

Figure #2: Cut stock caliper mounting ears as shown.

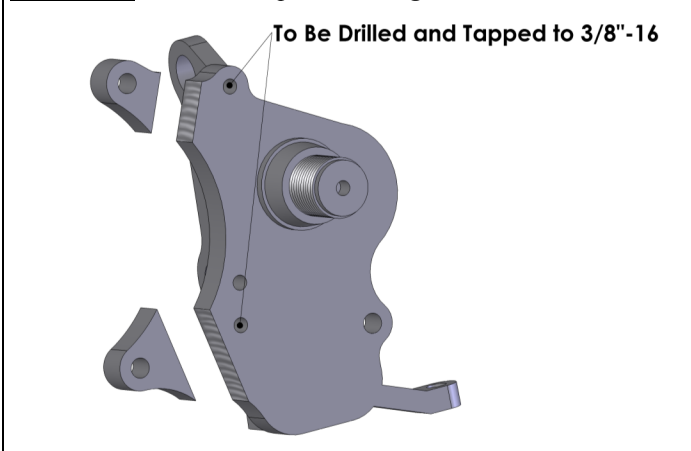

- 5.) Slide the rotor (2,3) over the wheel studs flush to the face of the wheel spacer. Rotors mount with the arrow pointing in the direction of normal rotation. (Figure 4)
Note: Minimum clearance between the caliper mounting bracket bolts and the inboard face of the rotor should be 1/16" (.0625").
- Please read B1850 instructions for complete 4-piston caliper instructions.

Figure #4: Rotors and Calipers are directional

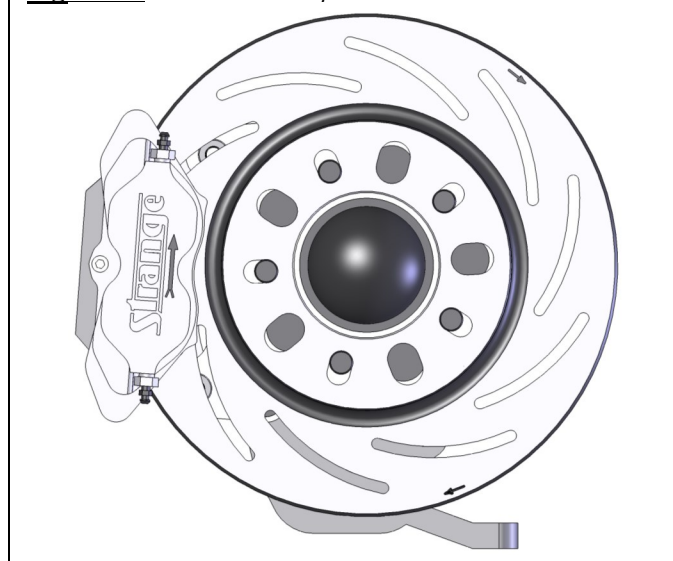

Note: After the initial installation of this kit, ensure that there is adequate clearance between all braking and chassis components by turning the wheels all the way left to right and moving them all the way up and down throughout the length of the wheel (suspension) travel. Additionally, make sure that the brake lines are not interfering with the wheel travel, or subject to binding or kinking. Operate the vehicle in a cautious manner until you determine that the brakes are functioning properly. Routinely check and re-torque all bolts.

WARNING – RACING IS HAZARDOUS · STRANGE BRAKES ARE FOR LEGAL DRAG RACING ONLY

Disclaimer of Warranty – Purchasers using Strange Engineering racing components and equipment any and all inventory services, purchasers acknowledge that due to differing conditions and circumstances under which all equipment and parts are installed and used, purchasers are not relying on Strange Engineering Co. skill or judgment to select or furnish the proper part or equipment. Purchasers expressly affirm they are relying upon their own skill or judgment to select and purchase suitable goods.

Strange Engineering Co. makes no warranties whatsoever, expressed or implied, oral or written, to purchasers. There is no warranty of merchantability made to purchasers. Strange Engineering Co., further excludes any implied warranty of fitness with respect to racing and equipment, any and all inventory and service.