

## 9" Center Section Guidelines & Torque Specifications

Item #	Part #	Description	Torque Spec.	Notes
1	N1912K	10-24 X 1/2 FHSCS	Hand-tight	Blue Loctite
2	F1282	3/8-24 Nut	35 ft-lbs	none
3	L7010AB	9/16-18 12 Point Nut	80 ft-lbs	Anti-seize
4	N1950C	3/8-24 x 1.25 ARP 12 Pt. Screw	35 ft-lbs	none
5a	N1922A	28 Spline Pinion Nut	200 ft-lbs	Red Loctite
5b	N1922B	35 Spline Pinion Nut	250 ft-lbs	Red Loctite
6	N1912U	7/8-14 Plug	40 ft-lbs	none
7	N1910	Load Bolt Assembly (optional)	see notes below	none
8a	N1975A	7/16-20 ARP 12 Pt. Screw	85 ft-lbs	Red Loctite
8b	N1976A	1/2-20 ARP 12 Pt. Screw	120 ft-lbs	Red Loctite
9a	N1905B	5/16-18 x 0.375 BHSCS	10 ft-lbs	none
9b	N1902D	5/16-18 x 0.625 BHSCS	10 ft-lbs	none
10	N2300E	7/16-14 x 1.50 ARP 12 Pt. Screw	50 ft-lbs	Anti-seize
11a	N1965	7/16-20 x 7/8" HHCS	85 ft-lbs	Red Loctite
11b	N1964	1/2-20 x 7/8" HHCS	105 ft-lbs	Red Loctite
11c	N1967	7/16-20 x 1" HHCS	85 ft-lbs	Red Loctite
11d	N1968	7/16-20 x 1-1/4" HHCS	85 ft-lbs	Red Loctite
12	B1757B	3/8-16 x 1.25" HHCS	35 ft-lbs	none
13	L4000J	3/8 NPT Socket Pipe Plug	40 ft-lbs	Thread Sealer
14	H1122D	1/2-20 x 3" SHCS	80 ft-lbs	Anti-seize
15	B1320R	3/8-16 x 1.50" HHCS	35 ft-lbs	none
16	N1908E	1/2 NPT Socket Pipe Plug	40 ft-lbs	Thread Sealer

### Gear Oil Type & Amount

- SAE 85W-140 gear oil is recommended
- 9" cases require 2.5 quarts of gear oil

### Break-in Procedure for Street Gears

1. No harsh acceleration!
2. Drive vehicle 50 miles
3. Allow 1/2 hour for cool down
4. Repeat for total of 250 miles
5. At 500 miles remove the center section, fully clean, use a fresh gasket & reinstall

### Load Bolt Set-up & Adjustment

1. Tighten load bolt while turning assembly by hand until drag is felt.
2. Loosen load bolt approx. .001" from contacting the ring gear.
3. Rotate assembly again. If drag is felt, loosen load bolt an additional 0.001". If no drag is felt, hold load bolt in place and tighten the jam nut
4. Load bolt may need readjustment after every 4-8 passes depending on frequency of runs.

### Differential Friction Modifier

- Required for clutch-type limited slip differentials
- One entire bottle (3.8 fl. oz.) is required in addition to the 2.5 quarts of gear oil.
- Ford Racing brand additive part # CM-19546-A1 is recommended.
- Additive is required even if gear oil manufacturer states oil is compatible with limited slip differentials.

### Storage of Center Sections

Differential bearings, pinion bearings, and ring and pinion should be liberally oiled with gear oil and then sealed from the atmosphere in a plastic bag.

### Tail Bearing Retainer Plate (shown below)

- Only Ultra & PRO HD Cases

### Center Section Removal

- Use provided jackscrews (18) to aid in removal of the center from the rear end. (only Ultra & Pro HD)
- Do not leave the jackscrew installed during operation

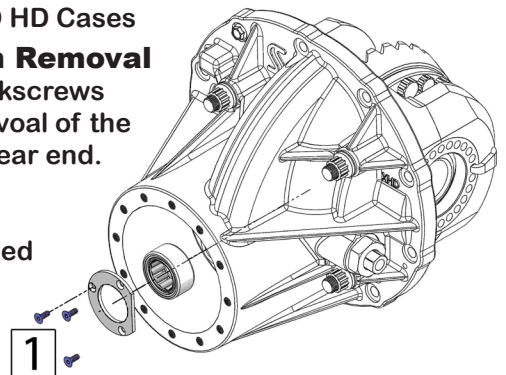

# Strange

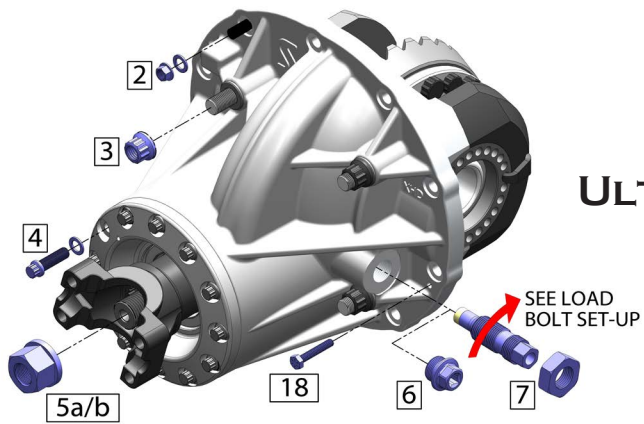

**ULTRA CASE**

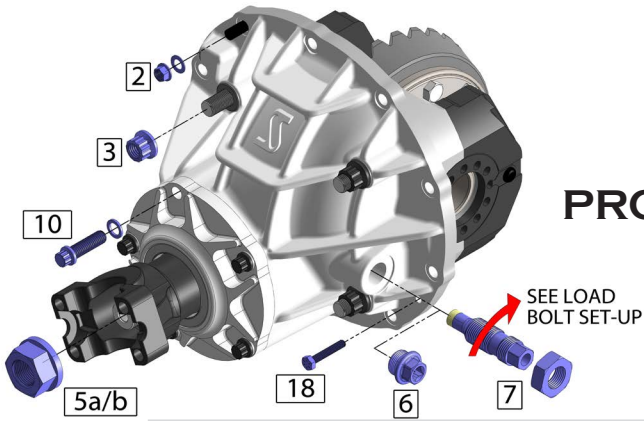
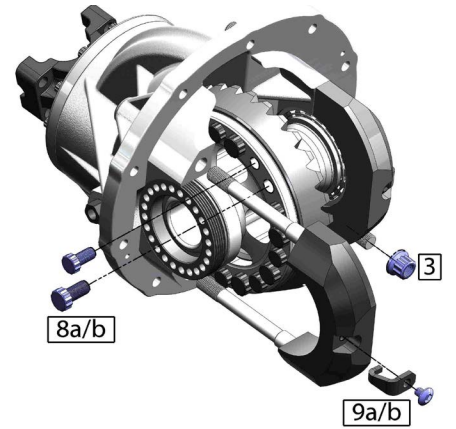

**PRO HD CASE**

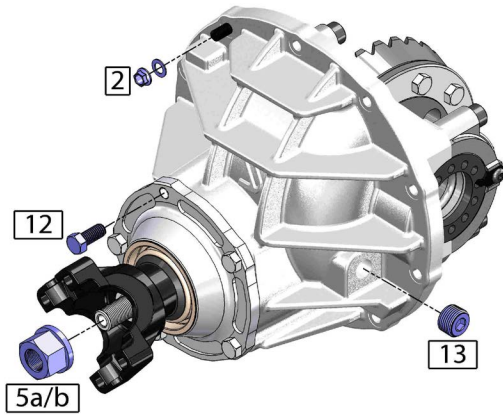
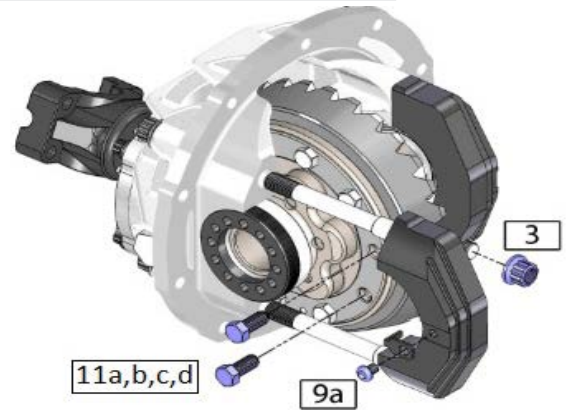

**PRO CASE**

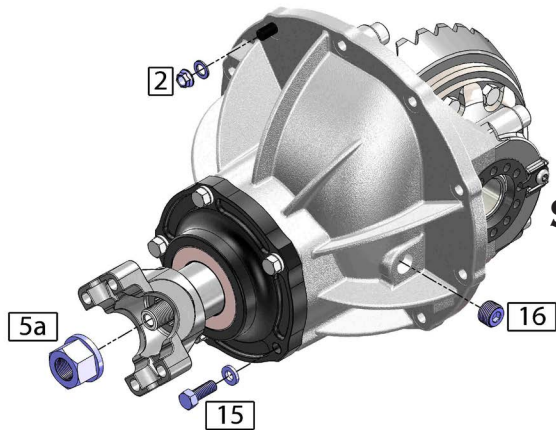
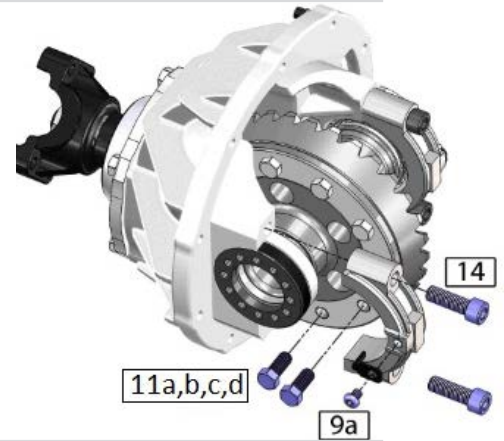

**STREET CASE**

