

Strange

Kit Summary:

Kit #	C4598WC
Description	10" front carbon brake kit for Strange Aluminum struts
Page	1 of 2 total pages
Date Modified	Jan 30, 2015

Kit Contents

ITEM#	PART#	QTY	DESCRIPTION
1	B1260L	2	strut spacer 0.125"
2	C1780	2	carbon rotor 10"
3	B1250E	16	10-24 x 3/8" FHSCS
4	B1250W	2	carbon rotor retaining ring
5	B1250S	2	carbon rotor adapter
6	S3402N	26	3/8" AN washer
7	F1282	18	3/8"-24 jet nut
8	S3402Q	4	3/8"-24 x 1-1/8" bolt
9	C4596D	4	3/8"-24 x 3-1/4" caliper bolt
10	C4596E	2	1/4"-28 x 3-1/4" caliper bridge bolt
11	B1260E	2	1/4" Vwasher
12	B1260CW	2	inboard "hotdog" bracket
13	B1260K	4	Garlock 05-DU06 bearing (<i>pre-installed in B1260CW</i>)
14	B3311C	4	caliper slide pin
15	B4598A	2	caliper mounting bracket
16	B1260BZ	2	caliper inner half
17	B5000P2	2	caliper piston
18	B5000T1	2	caliper piston o-ring (<i>pre-installed in B1260BY</i>)
19	P2316	2	1/8" x #3AN NPT fitting
20	P2365F	2	1/8" NPT bleeder assembly
21	L4000O	2	1/8" NPT socket plug
22	B1262J	2	bridge bolt tube
23	B1250P	4	carbon brake pad
24	B1260DW	2	outboard "hotdog" bracket
25	B1250H	4	Garlock 08-DU06 bearing (<i>pre-installed in B1260DW</i>)
26	B1260AW	2	caliper outer half
27	C4596B	2	1/4"-28 x 0.500 thread insert
28	H1150E	4	3/8"-24 x 0.520" thread insert

FIGURE # 1: Exploded view of C4598WC

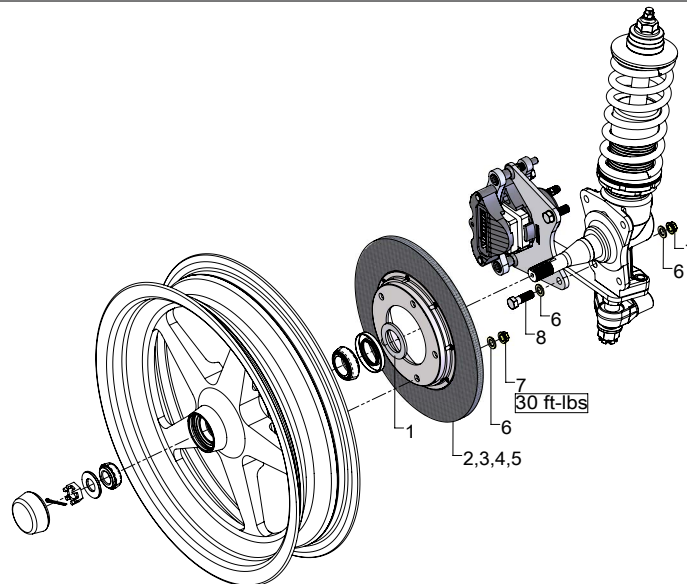

note: only components listed in the kit contents section are included

Brake rotors come pre-assembled from Strange Engineering. (figure 3)

1. Mount the rotor on the wheel using $\frac{3}{8}$ " studs supplied with the wheel and the $\frac{3}{8}$ " washers (6) and jet nuts (7) supplied with this brake kit. Torque to 30 ft-lbs.
2. Disassemble brake caliper by removing caliper bolts (9) and the caliper bridge bolt (10). The slide pins (14) should remain attached to the caliper mounting bracket.
3. Attach the caliper mounting bracket with the slide pins to the strut body using the two $\frac{3}{8}$ "-24 bolts (8), $\frac{3}{8}$ " washers (6) and jet nuts (7). Torque to 30 ft-lbs. Ensure bracket is in correct orientation.
4. Follow the strut kit instructions to assemble the wheel onto the spindle.
5. Slide the two caliper bolts with the $\frac{3}{8}$ " washers and the caliper bridge bolt with $\frac{1}{4}$ " washer (11) through the respective holes on the inboard "hotdog" bracket (12).
6. The caliper must now be assembled onto the caliper bracket. Slide the inboard "hotdog" bracket with the two caliper bolts and the caliper bridge bolt onto the inboard side of the caliper slide pins. The threads on the bolts should face outboard.
7. Feed the caliper inner half (16) over the rotor or through the outside of the wheel and slide through the two caliper bolts and the caliper bridge bolt.
8. Slide the carbon brake pad and caliper bridge bolt tube through the caliper bridge bolt.
9. Slide the outboard "hotdog" bracket through the two caliper slide pins, caliper bolts and caliper bridge bolt.
10. Align a carbon brake pad with the caliper outer half. Finally, line up caliper outer half and carbon brake pad with the two caliper bolts and the caliper bridge bolt. Loosely secure the two caliper bolts and caliper bridge bolt as the caliper outer half is attached.
Torque caliper bolts (9) to 30 ft-lbs and the bridge bolt (10) to 10 ft-lbs.
11. Connect the hydraulic lines to the calipers. Calipers are tapped to $\frac{1}{8}$ "-27 NPT and supplied with -3AN fitting. Use proper adapters to connect to existing lines or use new -3AN braided steel line (Teflon lines). Bleed calipers with DOT 4 or DOT 5.1 brake fluid only!

carbon brake notes:

Keep Carbon away from all chemicals. If contamination occurs the carbon component must be baked for 8 hours @ 500° F- (Bake Carbon ONLY! REMOVE ALUMINUM HAT & HARDWARE BEFORE BAKING)- If badly contaminated an odor will occur.

The hotter the rotors become, the MORE EFFECTIVE braking becomes. Carbon brakes will stop your vehicle far better at the "top end" and will not "hold" as well at the starting line, compared to steel brakes. We recommend that when you first drive or "tow" your vehicle to the starting line, you apply the brakes several times to get the "feel" of carbon at low speeds. After you become comfortable with the vehicle at "pit area" speeds, you may want to "drag" the brakes to create rotor and pad heat to better hold the vehicle at the starting line. We recommend a few 1/2 or 3/4 passes, so as to become aware of how your carbon brakes perform at higher M.P.H. Remember carbon works better at higher temperature. The longer the brakes are applied the more aggressive braking will become.

FIGURE # 2: Exploded view of brake caliper

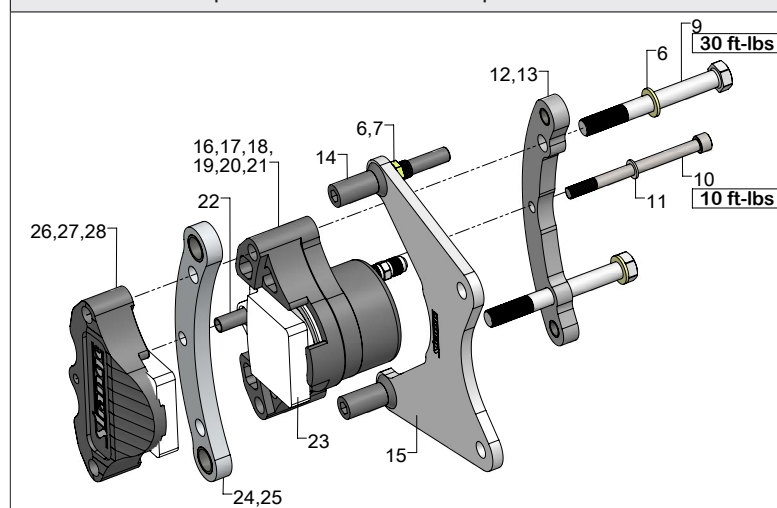

FIGURE # 3: Brake rotor assembly

