

# Strange

*Engineering*

8300 North Austin Avenue · Morton Grove IL 60053 · 847-663-1701 · Fax 847-663-1702 ·

Installation instructions for B4122WC heavy duty (4-piston) front brake kit for various late 70's through 80's Buicks, Chevys and Oldsmobiles.

**Before you begin installation:** Strange Engineering brake kits are designed for **DRAG RACING ONLY!** Read these instructions thoroughly and save for future reference. If after reading these installation instructions, you have any questions or comments, please do not hesitate to call us.

## KIT CONTENTS

<u>Item#</u>	<u>Part#</u>	<u>Qty.</u>	<u>Description</u>
1	A1028A	10	1/2"-20 x 2.5" Wheel stud
2	A1028B	10	1/2" I.D. Wheel stud washer
3	B4122D	4	3/8"-16x 1-1/2" FHSCS
4	B1301E	4	3/8"-24 Press nut (Installed in B4122CL & B4122CR)
5	B1320H	2	Inner hub bearing cup (Timken LM67010 installed in B1324A)
6	B1320J	2	Inner hub bearing cone (Timken LM67048)
7	B1324A	2	Front hub "F" 4.75" B.C.
8	B1330C	2	Outer hub bearing cup (Timken LM12710 installed in B1324A)
9	B1729A	2	Hub seal (C.R. 19748)
10	B1757C	2	Outer hub bearing cone (Timken LM12748F)
11	B1301H	16	3/8" I.D. x 0.025" Thick caliper shim
12	B1301J	4	3/8" I.D. x 1/16" Thick caliper washer
13	B5000Y	4	3/8"-24 x 1.125" Caliper bolt
14	B5010	4	Soft Metallic 4-piston caliper pad
15	B5002	1	Right hand 4-piston caliper
16	B5004	1	Left hand 4-piston caliper
17	P2316	2	1/8" NPT x -3AN Fitting (Installed in B5002 & B5004)
18	B2795	1	Right hand HD/MD tapered rotor
19	B2796	1	Left hand HD/MD tapered rotor
20	B4122CL	1	L.H. Caliper Mounting Bracket
21	B4122CR	1	R.H. Caliper Mounting Bracket
22	B4154E	2	Aluminum hub cap
23	S3520F	2	#222 Buna O-ring (Installed on B4154E)
24	B4122A	2	3/8" ID x 3/4" Long Stand
25	B4122B	2	3/8" ID x 0.675" Long Stand

<u>Item #</u>	<u>Torque Spec (ft-lbs.)</u>
1	65
3	35
13	35

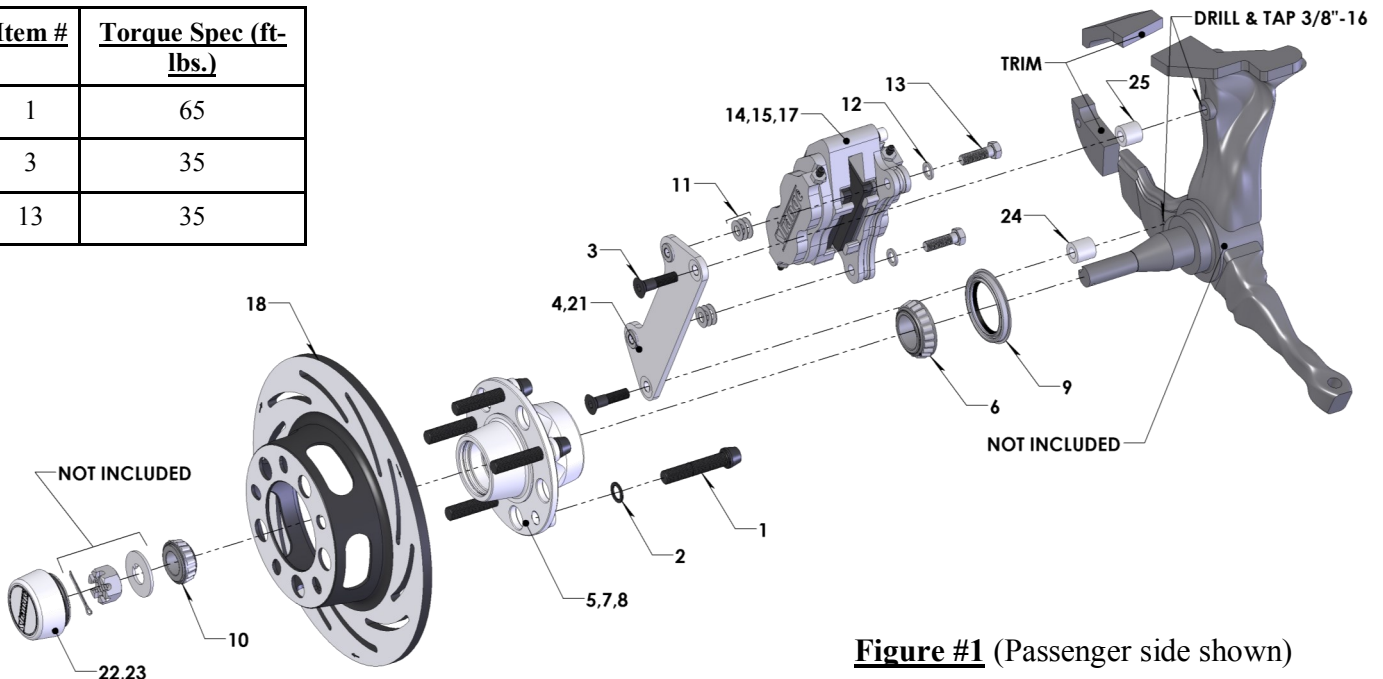

**Figure #1** (Passenger side shown)

## Installation Instruction

- 1.) Raise and support front of vehicle on a level surface using suitable equipment.
- 2.) Remove wheel, stock disc, hub, brake line, and backing plate/caliper assembly from spindle.
- 3.) Clean and inspect spindle for damage (spun wheel bearings, stripped threads, etc.) and repair or replace as needed. Inspect upper and lower ball joints for excessive play and replace as needed.
- 4.) Trim off the upper and lower caliper mounting ears at a distance of approximately 1" from the center of the caliper mounting bracket holes as shown in fig 1, to make room for new caliper.
- 4.) Drill and tap the caliper mounting bracket holes in the spindle 3/8"-16 (see figure 1). The top mounting hole should be drilled and tapped 1" deep. Drill and tap the bottom hole through.
- 5.) Beginning with the top mounting hole on the spindle body, attach the caliper mounting bracket (20,21) to the spindle. A 0.675" stand (25) is to be used at the top mounting hole, and a 3/4" stand (24) is to be used for the bottom mounting hole. Secure the bracket with the flat head cap screws (3). Torque to 35 ft-lbs.

**Note:** The press nuts (4) **MUST** face outboard.

- 6.) Install 1/2" Dia. wheel studs (1) in front hub (7) using 1/2" I.D. wheel stud washer (2) and a small amount of BLUE Loc-tite®. Torque all studs to 65 ft-lbs.

**Note:** Consult your wheel and/or lug nut manufacturer for proper lug nut torque.

- 7.) Pack the inboard (6) and outboard bearing cone (10) with NLGI 1 wheel bearing grease.

**Note:** A bearing packer is recommended for this procedure. If one is not available work as much grease as possible into the cage and around the rollers.

- 8.) Wipe a thin layer of wheel bearing grease on the bearing surface of the inner and outer cups (5, 8) and slide the inboard bearing cone (6) into hub (7).

- 9.) Press the hub seal (9) into the inboard side of the hub (7) flush to the outside.

- 10.) Slide the hub assembly onto the spindle then slide the outer bearing cone (10) into the hub (7).

- 11.) Install the stock spindle washer and nut.

- 12.) Mount the wheel and tire assembly on the hub and snug the lug nuts.

- 13.) While rotating the wheel, torque the spindle nut to approximately 20 ft-lbs.

- 14.) Loosen the spindle nut until the wheel spins freely and there is no end play.

- 15.) Install the cotter pin, aluminum hub cap (22), and remove the wheel and tire.

- 16.) Slide the rotor (18, 19) over the wheel studs flush to the face of the hub (7).

**Note:** Slotted rotors mount with the arrow pointing in the direction of normal rotation (See Figure #2).

**- Please read B1850 instructions for complete caliper instructions.**

- 17.) Attach caliper (15, 16) with the arrow facing in the direction of normal rotor rotation using 3/8"-24 caliper bolts (13) and 3/8" I.D. flat washers (12). Use 3/8" I.D. caliper shims (11) to center the caliper over the rotor, making sure pads contact the rotor evenly. Use any remaining shims under the head of the 3/8" Dia. Caliper bolt to prevent the bolt from contacting the rotor. Torque the caliper mounting bolts (13) to 35 ft-lbs.

- 18.) Connect the hydraulic lines to the calipers. Calipers are tapped to 1/8"-27 NPT and supplied with -3AN fittings. Use proper adapters to connect them to existing lines or use new -3AN braided steel line (teflon lined). Bleed the calipers with DOT 4 or DOT 5.1 brake fluid **ONLY**.

- 19.) A proper break in procedure is required to avoid brake fade and uneven rotor deposits from the pads. It consists of 8-10 brake applications increasing in harshness while allowing the brakes to cool slightly in between; do not keep the brakes applied between stops. After the last stop the brakes should be allowed to cool completely.

**Note:** After the initial installation of this kit, ensure that there is adequate clearance between all braking and chassis components by turning the wheels all the way left to right and moving them all the way up and down throughout the length of the wheel (suspension) travel. Additionally, make sure that the brake lines are not interfering with the wheel travel, or subject to binding or kinking. Operate the vehicle in a cautious manner until you determine that the brakes are functioning properly. Routinely check and re-torque all bolts.

**Figure 2:** (Passenger Side Shown)

*Rotors and calipers are directional*

*Mount with arrow pointing in direction of normal rotor rotation*

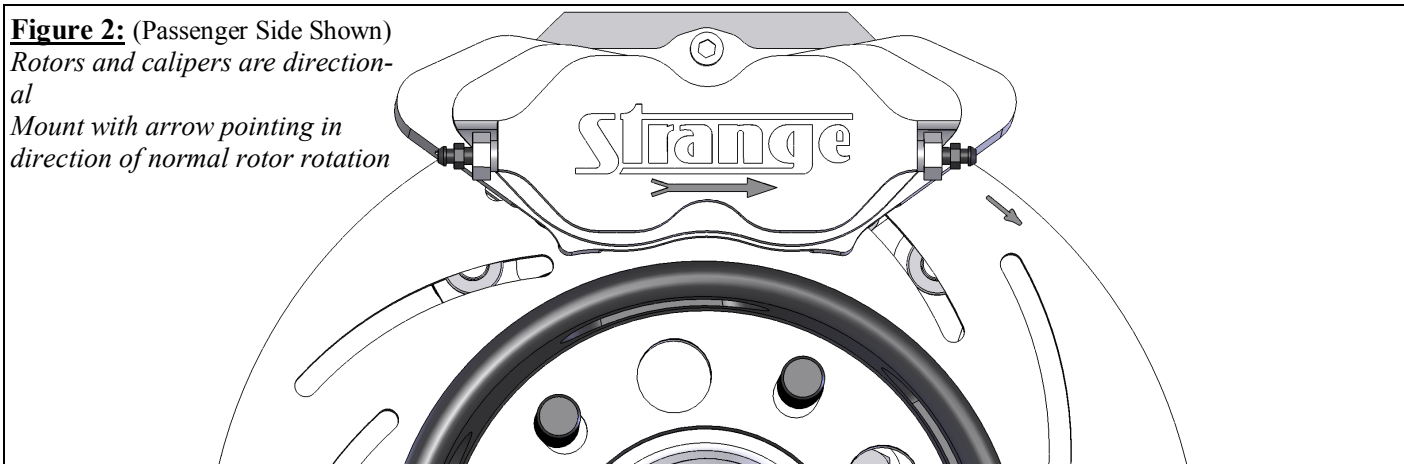

### **WARNING – RACING IS HAZARDOUS · STRANGE BRAKES ARE FOR LEGAL DRAG RACING ONLY**

**Disclaimer of Warranty –** Purchasers using Strange Engineering racing components and equipment any and all inventory services, purchasers acknowledge that due to differing conditions and circumstances under which all equipment and parts are installed and used, purchasers are not relying on Strange Engineering Co. skill or judgment to select or furnish the proper part or equipment. Purchasers expressly affirm they are relying upon their own skill or judgment to select and purchase suitable goods.

Strange Engineering Co. makes no warranties whatsoever, expressed or implied, oral or written, to purchasers. There is no warranty of merchantability made to purchasers. Strange Engineering Co., further excludes any implied warranty of fitness with respect to racing and equipment, any and all inventory and service.