

F5010 PRO TOURING FLOATER KIT

Installation to be performed by a qualified technician.

Optional Brake Kit

- B2711WC Black Calipers & 12.19" Brake Discs
- B2711WCR Red Calipers & 12.19" Brake Discs
- B2714WC Black Calipers & 14.00" Brake Discs
- B2714WCR Red Calipers & 14.00" Brake Discs

RaceStrange

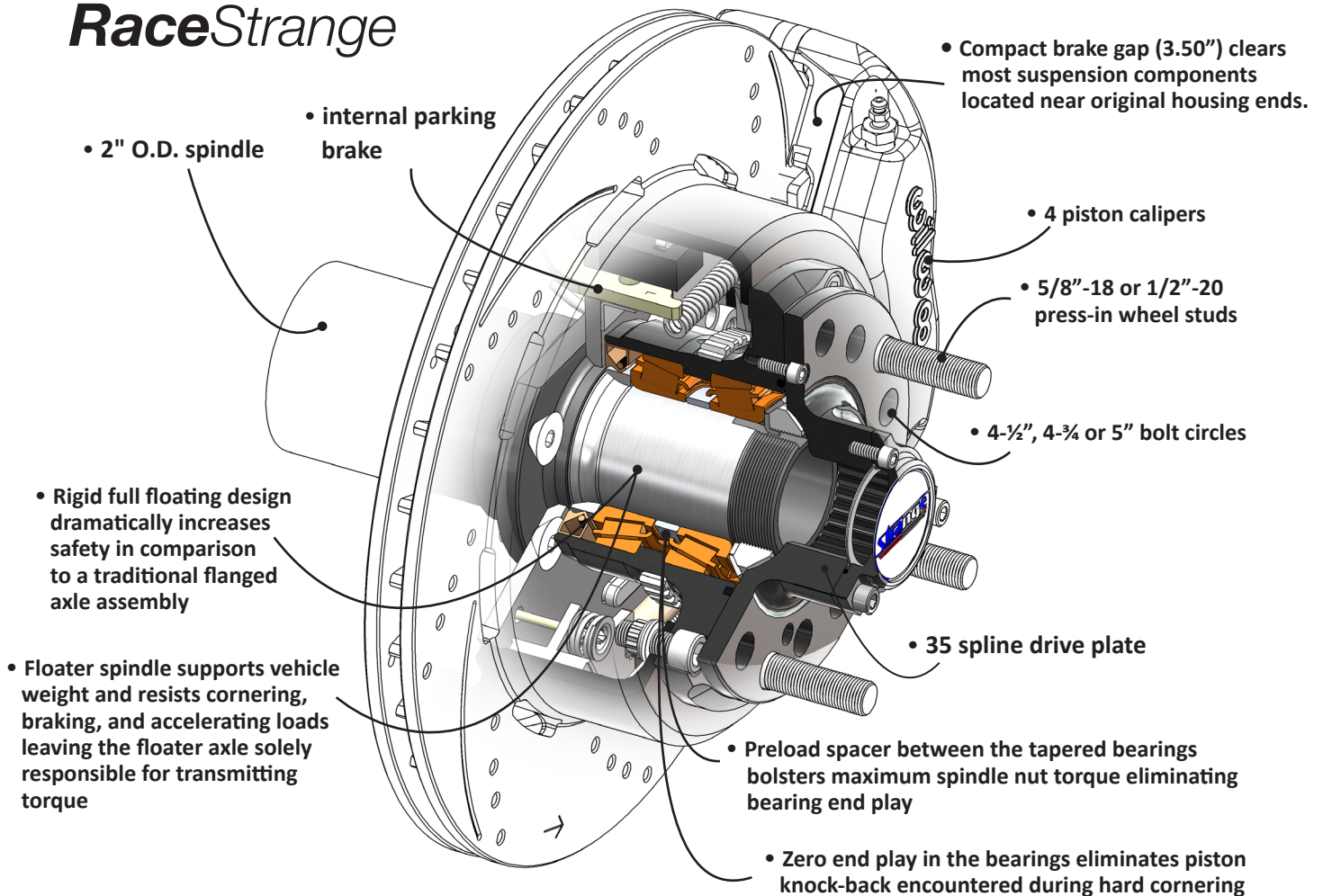

P5010 KIT CONTENTS

| ITEM# | PART# | QTY | DESCRIPTION |
|-------|--------|-----|-------------------------|
| 1 | A1050D | 6 | 1/4-28 x 3/4" SHCS |
| 2 | F5056F | 2 | Floater cap |
| 3 | A1RS | 2 | Decal |
| 4 | F2200B | 2 | O-Ring -032 |
| 5 | F5056L | 4 | 10-24 x 1/2" SHCS |
| 6 | F5056A | 2 | Drive Plate |
| 7 | A1024B | 2 | O-ring -237 |
| 8 | F5056C | 2 | Spindle nut |
| 9 | F5056D | 2 | Spindle nut retainer |
| 10 | N1948 | 4 | Timken bearing LM104949 |
| 11 | F5056E | 2 | Preload spacer |
| 12 | F5056K | 10 | 3/8-24 x 3/4" SHCS |
| 13 | F5056H | 2 | Drive hub |

| ITEM# | PART# | QTY | DESCRIPTION |
|-------|--------|-----|--|
| 14 | N1949 | 4 | Timken cup LM104911 (pre-installed) |
| 15a | A3164A | 10 | 1/2-20 x 3.115 press-in stud (optional) |
| 15b | A3166A | 10 | 5/8-18 x 3.115 press-in stud (optional) |
| 16 | S3402N | 10 | 3/8" washer |
| 17 | F1282 | 10 | 3/8-24 jet nut |
| 18 | F5056J | 2 | Seal national 413246N |
| 19 | F5056B | 2 | Spindle ring |
| 20 | F1237D | 10 | 3/8-24 x 3/4" FHSCS |
| 21 | F5056G | 2 | Street floater spindle |
| 22 | F5056W | 1 | Spindle spanner wrench |
| 23 | F5056O | 2 | ABS sensor screw M8 x 1.25 x 14mm BHSCS (optional) |
| 24 | F5056N | 2 | ABS sensor spacer (optional) |
| 25 | F5056M | 2 | Reluctor ring (optional) |

SPINDLE DIMENSIONS, WELDING INSTRUCTIONS & WHEEL CLEARANCE

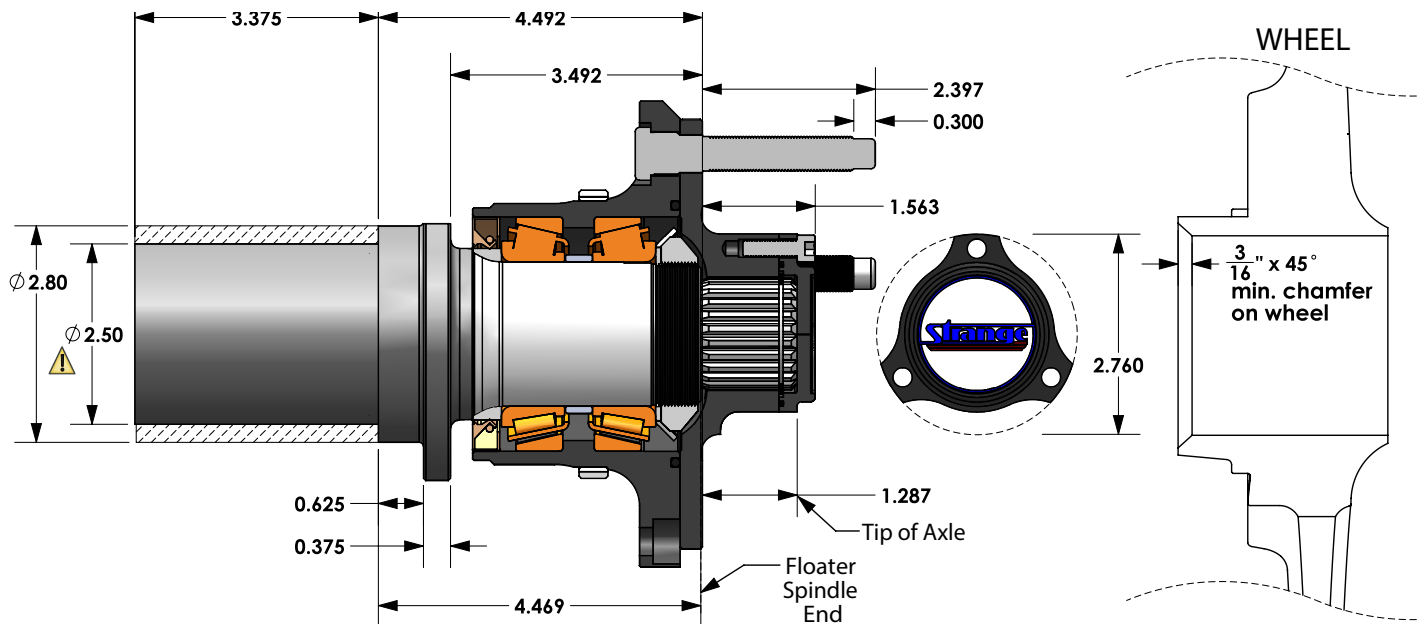

NOTE: 2.50" inside diameter of housing tubes may vary. Please refer to step # 2 for instructions.

The dimensions above apply to all kits with either 1/2" or 3/8" wheel studs.

Ensure wheels will fit this kit.

The wheel bore must be greater than 2.760 as shown. In addition, the chamfer shown must be greater than 3/16.

WELDING GUIDELINES

A professional and qualified chassis shop **MUST** perform the welding of the spindles to the housing tubes. This is very important due to the fact that if care is not taken in this crucial step leaks can occur, the axles could bind, and erratic handling could result from misaligned spindles.

1. All spindles are constructed from normalized aircraft quality 4130 hot rolled steel. The spindles are black oxidized for cosmetic purposes which does not effect the welding process.
2. The street floater spindles have 2.800" outside diameter that must be turned down to fit the specific housing tube inside diameter. Typically the inside diameter is 2.50" but can vary. A suggested starting point is to turn the spindle down 0.001" smaller than the measured housing tube inside diameter for a slip-fit leaving 0.625" un-machined from the backside of the flange as shown. This will provide a stop against the housing tube and give sufficient clearance to weld the spindle to the housing tube. Once both spindles fit into the housing, a line up bar must be used to verify straightness. If the line up bar does not pass through both spindles, then the outside diameter of the spindles must be turned down further and checked again with the line up bar. Do not turn down the diameter more than necessary.
3. Drill 0.375" to 0.500" holes in the housing tube only (**note the spindle**) to facilitate plug welding. Drill two holes 180 degrees to each other in two locations (four holes per spindle) where feasible.
4. Weld the spindle 360 degrees to the end of the housing tube. The weld must be leak free.

Installation Notes

- Clevis and cable kit which attach to the parking brake assembly are not included in Wilwood parking brake kit. Contact Wilwood to order cable kit separately.
- Use the assembly diagram shown on page 4 to install the components. If you have any questions, concerns or comments please feel free to contact Strange Engineering.
- For specific brake information including wheel clearance and brake testing please refer to Wilwood instructions attached at the end of this document.
- Prior to installing the bearings (10), ensure to pack the bearings with a high quality wheel bearing grease (NLGI #1 or NLGI #2). A bearing packer is recommended. Otherwise, work as much grease as possible by hand around the rollers.
- After installation rotate the hub and ensure all the components have seated properly.

Hub Seal Installation

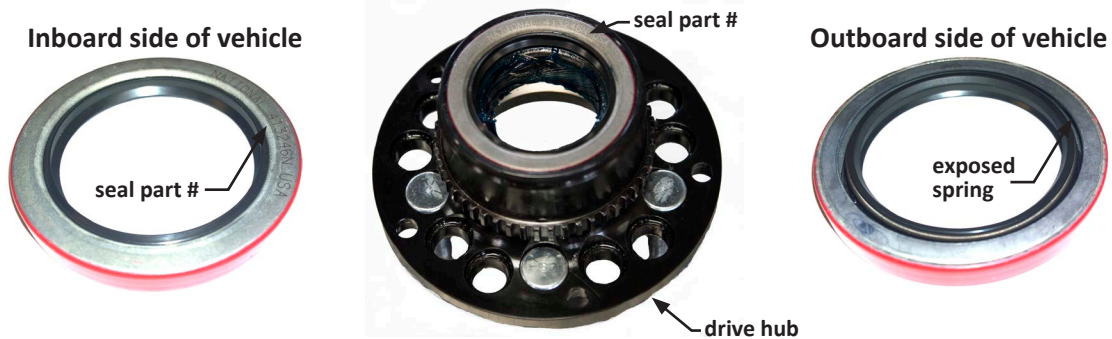

Ford Mustang ABS Sensor Information

- ABS sensor must be installed before mounting the parking brake assembly on the spindle
- Parking brake assembly will have to be disassembled to install the sensor.
- 2011- present Mustang will use sensor spacer (24)
- 2010 and earlier Mustang will not use sensor spacer

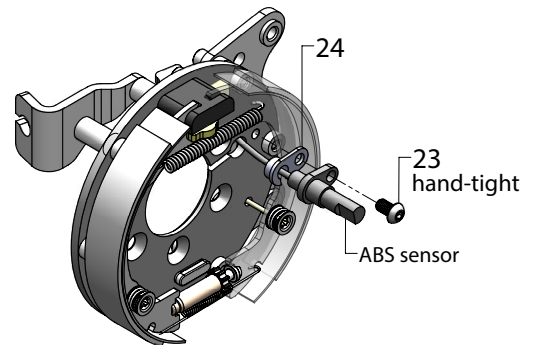

Axle Nut Installation

1. Ensure the tab on the inside diameter of the spindle nut retainer (9) slides into the groove of the spindle shaft.
2. The spindle nut is installed using the spindle nut wrench (22). Torque the spindle nut to 50-60 ft-lbs.
3. Bend one of the tabs on the outside diameter of the spindle nut retainer (9) into the slots on the spindle nut.

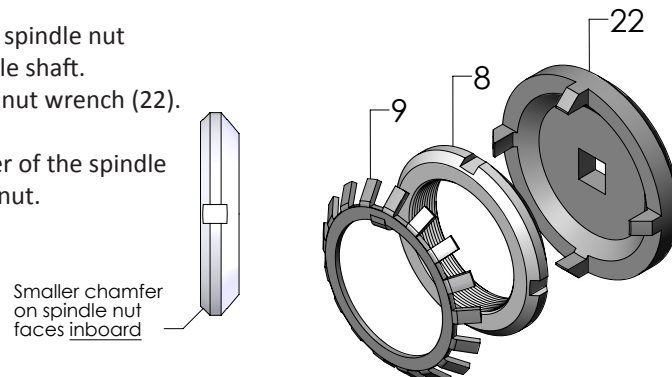

Exploded View of Steer Floater Assembly

