

# Strange

## Engineering

### Kit Summary:

Kit #	A1033
Description	C-clip eliminator kit
Applications	stock GM G-body (78-84) axles in factory housing end (does not fit 7.50"/7.625" GM housing end)
Page	1 of 2 total pages
Date Modified	Dec 20, 2013

### Kit Contents

ITEM#	PART#	QTY	DESCRIPTION
1	A1033B	2	Safety Hub Outter Half ( <i>threaded half</i> )
2	A1090F	2	Outboard Axle Seal
3	A1011	2	Timken Tapered Axle Bearing
4	A1033C	2	Stock Axle Bearing Sleeve
5	A1032D	2	Wedding Ring
6	A1023R	2	O-Ring
7	A1033A	2	Safety Hub Inner Half
8	A1030C	2	Inboard Axle Seal
9	A1030E	4	Housing End Gaskets
10	A1030G	2	GM Safety Hub Stud (optional)
11	S3402N	2	3/8" Washer (optional)
12	F1282	2	3/8"-24 Jet Nut (optional)
13	A1030D	8	3/8"-16 x 2" Bolts

#### Housing Preparation (*refer to figure 1*)

1. Remove wheel and tire, drum and axle from the housing (axle c-clip must be removed first).
2. Disassemble the rear drum kit and remove the studs and backing plate from the housing end flanges.
3. Remove the stock bearing and seal from the housing snouts.
4. Refer to figure 1 and shorten the housing snout leaving the register for the backing plate only.
5. Grind a 1/8" chamfer on the inner diameter to provide clearance for the wedding ring. Remove any burrs.
6. Remove any rust, dirt or grease from the modified housing and both seating surfaces of the backing plate.

**Note:** G-body style housings will require modification of the backing plate (*refer to figure 2*)

Grind the backing plate slightly as shown so the safety hub inner half seats flat on the outboard surface.

Using the safety hub inner half as a jig open the bottom holes to 3/8" and drill the top two 3/8" holes on the backing plate and housing end.

7. Slide the bolts (13) through the housing end flange.  
**Note:** Use the provided stud (10) instead of the bolt in locations where clearance may be an issue due to the stock shock mount brackets.
8. Apply a thin coating of RTV sealer to both sides of hub gaskets (9).
9. Re-install the brake backing plate with gaskets.

#### Axle Preparation (*refer to figure 3,4*)

10. Press the safety hub outer half (1), outboard axle seal (2), stock axle bearing sleeve (4) and the axle bearing (3) on the axle.

**Note:** The bearing must be pressed on the correct distance. Ensure this by referencing to figure 3. The distance between the axle flange and inboard side of the safety hub outer half is 1.830"

11. Press the wedding ring (5) on the axle until fully seated against the bearing.
12. Slide the o-ring (6) evenly on the axle bearing.
13. Slip the safety hub inner half (7) and the inboard axle seal (8) over the axle bearing and wedding ring.

#### Axle Installation (*refer to figure 4*)

14. The button on the end of the stock axles must be completely cut off to avoid contact with the variety of differential units.
15. Coat the spline portion of the axle with white lead compound or grease. This will help determine axle spline engagement.
16. Re-install the axle with the safety hub assembly and rotate the safety hubs to align with the bolts (13).  
Due to a variety of differentials and gear ratios ensure the axle shafts do not contact the differential cross pin. The axle must be cut if it makes any contact. Contact can be checked by coating the ends of the axle with white lead or grease.
17. Remove the axle from the housing and ensure spline engagement is 1" minimum.
18. Re-assemble the axle into the housing and torque the housing end bolts (13) to 40 ft-lbs.

**FIGURE # 1: Housing End Modification**

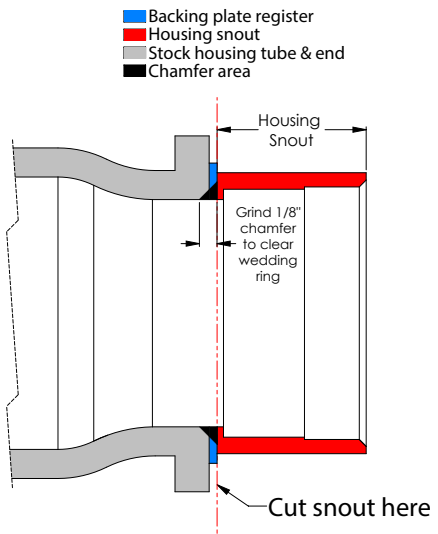

**FIGURE # 2: G-Body Backing Plate Modification**

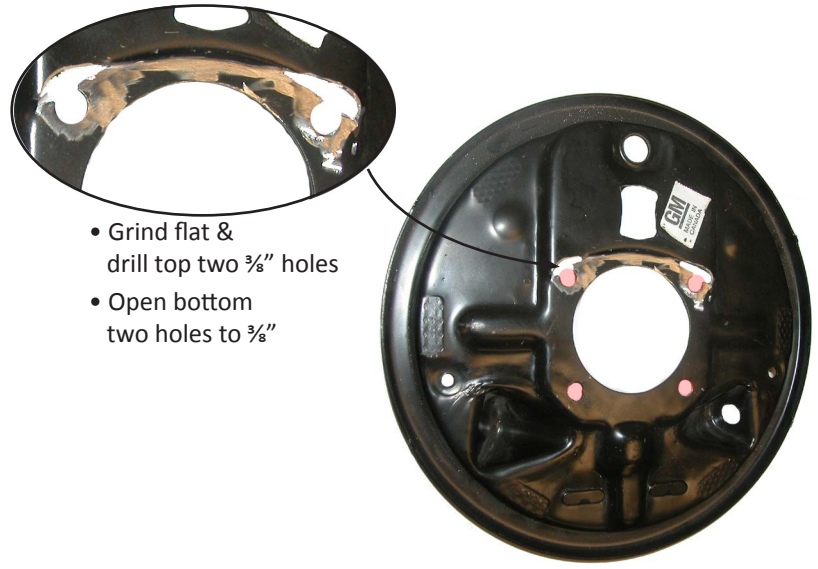

**FIGURE # 3: Tapered Axle Bearing Press Distance**

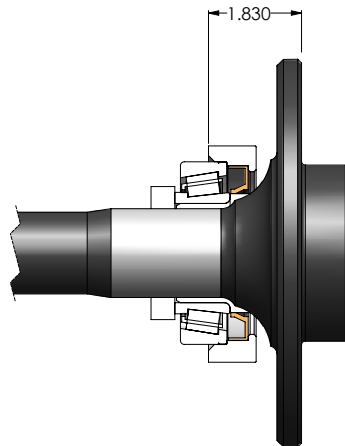

**FIGURE # 4: Exploded view**

