

Installation instructions for D1581 spool bearing set used on a D1530 33 spline aluminum spool in GM 12 bolt applications.

Before you begin installation: This kit is designed for **DRAG RACING ONLY!** These instructions do not cover installation and set-up of the gear set. Refer to the instructions provided by the gear set manufacturer. Read these instructions thoroughly and save for future reference. If after reading these installation instructions, you have any questions or comments, please do not hesitate to call us.

KIT CONTENTS

<u>Item#</u>	<u>Part#</u>	<u>Qty.</u>	<u>Description</u>
1	D1581A	2	Modified spool bearing cup (Timken #L305610)
2	D1581B	2	Spool bearing cone (Timken #L305649)
3	R5214D	1	Passenger side bearing spacer 1/4" thick
4	R5214G	1	Driver's side bearing spacer 5/16" thick

- 1.) Clean spool bearing journals and inside diameter of spool bearing cones (2) and apply a light coating of oil to both surfaces. Press spool bearing cones (2) evenly onto spool until fully seated by pressing on the inner race only. Ensure that the larger side of the bearing cone (2) faces the spool.
- 2.) Slide spool bearing cups (1) onto bearing cones (2).
- 3.) Next, place the side bearing spacers (3 & 4) on top of the spool bearing cups (1). (**WARNING!**, If the side bearing spacers are not installed, the bearing cones (2) will rub on the side shims causing bearing failure.
- 4.) Finally, install the appropriate amount of side shims from your gear installation kit as required by your gear set manufacturer's instructions and install the assembly into rear end housing.

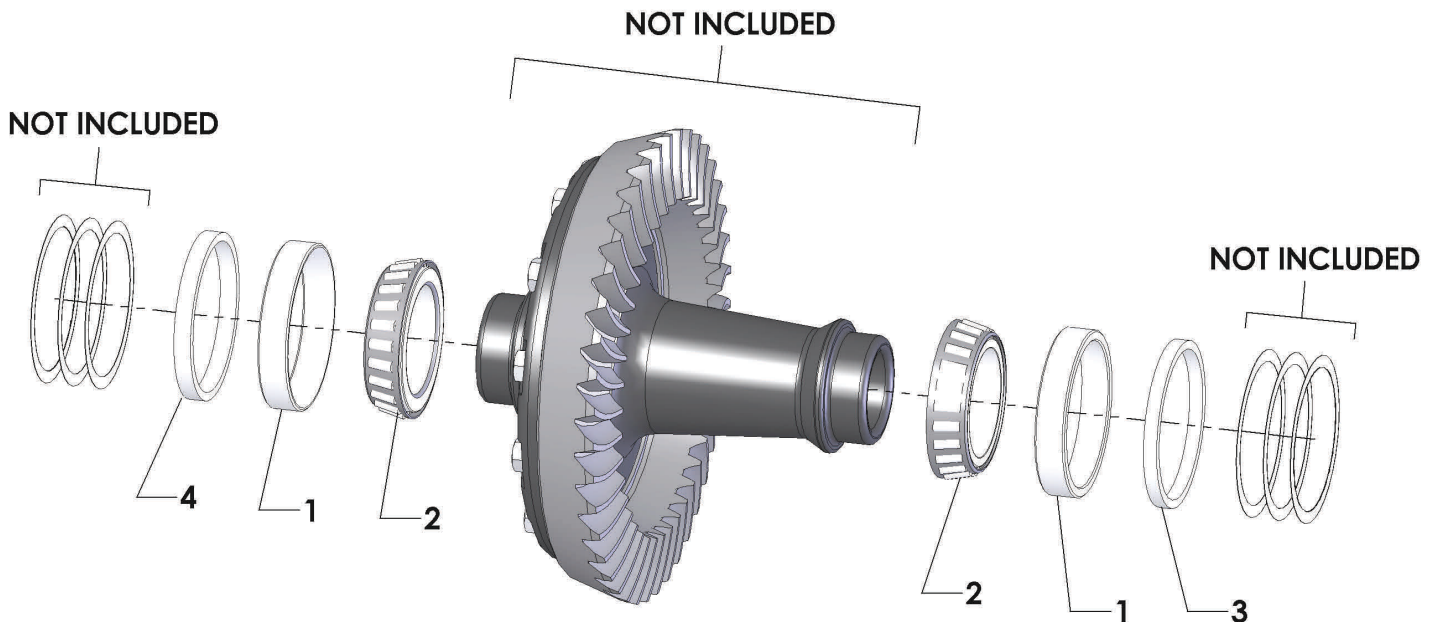

WARNING – RACING IS HAZARDOUS · THIS KIT IS FOR LEGAL DRAG RACING ONLY

Disclaimer of Warranty – Purchasers using Strange Engineering racing components and equipment any and all inventory services, purchasers acknowledge that due to differing conditions and circumstances under which all equipment and parts are installed and used, purchasers are not relying on Strange Engineering Co. skill or judgment to select or furnish the proper part or equipment. Purchasers expressly affirm they are relying upon their own skill or judgment to select and purchase suitable goods.

Strange Engineering Co. makes no warranties whatsoever, expressed or implied, oral or written, to purchasers. There is no warranty of merchantability made to purchasers. Strange Engineering Co., further excludes any implied warranty of fitness with respect to racing and equipment, any and all inventory and service.