

Strange

Engineering

8300 North Austin Avenue · Morton Grove IL 60053 · 847-663-1701 · Fax 847-663-1702 · www.strangeengineering.net

B2794 HD ROTOR INSTRUCTIONS

COMPONENTS:

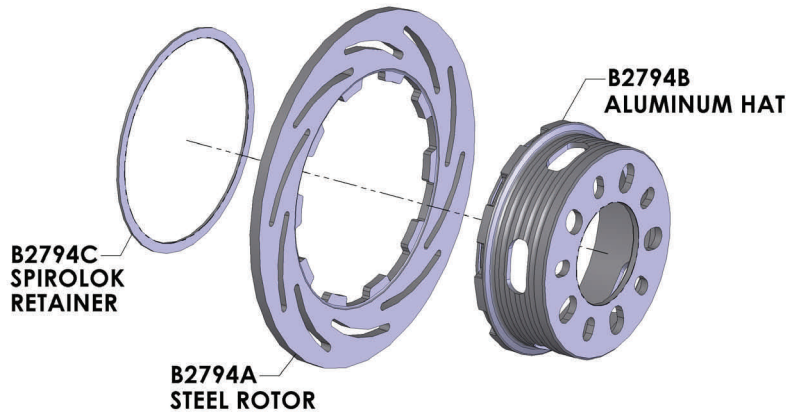

SPECIFICATIONS:

- 11-1/4" O.D. rotor
- 0.355" thick rotor
- 1/4" thick hat
- 3-1/4" pilot I.D. in hat
- Accepts axle flange O.D. 6.245" or smaller
- 4-1/2" - 5" uni-lug bolt circle accommodates 1/2" and 5/8" studs
- ASTM A36 steel rotor
- Forged 2014-T4 aluminum hat

FEATURES & BENEFITS:

- Floating rotor design allows for axial and radial growth of rotor as temperature increases which greatly reduces warping and coning tendencies
- Non-directional hat
- Unisex rotor design
- No bolts to come loose or safety wire to mess with
- Easier to resurface
- Assembled rotor weighs 6.5 lbs. verses 7.2 lbs. for 1 pc. steel rotor

CALIPER REQUIREMENTS:

- Brake calipers must measure 0.695 or larger between the brake pad tabs in order to clear the rotor
- If necessary, the calipers can be modified by removing an even amount of material off the 4 brake pad tabs until the distance between them is 0.695 or larger.

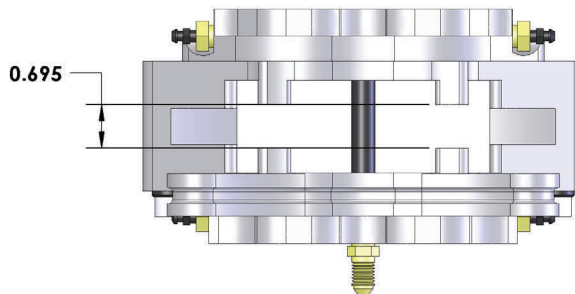

WARNING – RACING IS HAZARDOUS · STRANGE BRAKES ARE FOR LEGAL DRAG RACING ONLY

Disclaimer of Warranty – Purchasers using Strange Engineering racing components and equipment any and all inventory services, purchasers acknowledge that due to differing conditions and circumstances under which all equipment and parts are installed and used, purchasers are not relying on Strange Engineering Co. skill or judgment to select or furnish the proper part or equipment. Purchasers expressly affirm they are relying upon their own skill or judgment to select and purchase suitable goods.

Strange Engineering Co. makes no warranties whatsoever, expressed or implied, oral or written, to purchasers. There is no warranty of merchantability made to purchasers. Strange Engineering Co., further excludes any implied warranty of fitness with respect to racing and equipment, any and all inventory and service.