

Installation instructions for Strange Pro Race 11" Rear Carbon Brake Kit for Olds Housing ends with 4.75" (C18004UC) or 5" (C18005UC) Bolt Circle

Important Notes:

- Strange Engineering brake kits are designed for **DRAG RACING ONLY!**
- Carbon brake pads (L4050H1 & L4050H2) minimal thickness is 0.200".
- 11" Carbon rotors (C1790) minimal thickness is 0.300".

Before you begin installation:

Read these instructions thoroughly and save for future reference.

If after reading these installation instructions, you have any questions or comments, please do not hesitate to call us.

KIT CONTENTS

Item#	Part#	Qty.	Description
1	B1300H	8	3/8-24 X 1-1/4" T-Bolt
2	S3402N	8	3/8" AN Washer
3	F1282	8	3/8-24 "Jet" Nut
4	C1700A	2	Carbon Ultra Caliper Mounting Bracket
5	B1301E	4	3/8"-24 Press Nut
6*	C1700B*	1*	R.H. carbon rotor adaptor for use with 4 3/4" b.c. (C18004UC)
6*	C1700F*	1*	R.H. carbon rotor adaptor for use with 5" b.c (C18005UC)
7*	C1700C*	1*	L.H. carbon rotor adaptor for use with 4 3/4" b.c. (C18004UC)
7*	C1700G*	1*	L.H. carbon rotor adaptor for use with 5" b.c (C18005UC)
8	C1700D	20	1/4"-20 x 1/2" FHSCS
9	C1700H	2	11" Carbon rotor retainer ring
10	C1790	2	11" Carbon rotor
11	B5000Z	4	3/8"-24 x 1.187" Caliper mounting bolt
12	S3402L	4	Forged S/A Bushing (Installed in B5006 & B5008)
13	B5006	1	R.H. Carbon Ultra Caliper (w/ ceramic inserts)
14	B5008	1	L.H. Carbon Ultra Caliper (w/ ceramic inserts)
15	L4050H1	2	Slotted (directional) 4-piston carbon pad
16	L4050H2	2	Slotted (directional) 4-piston carbon pad
17	P2316	2	1/8" NPT x #3 AN Fitting (installed in B5006 & B5008)

*Kit contents will depend on application based on bolt circle diameter. (does not affect assembly)

Figure #1: Driver Side

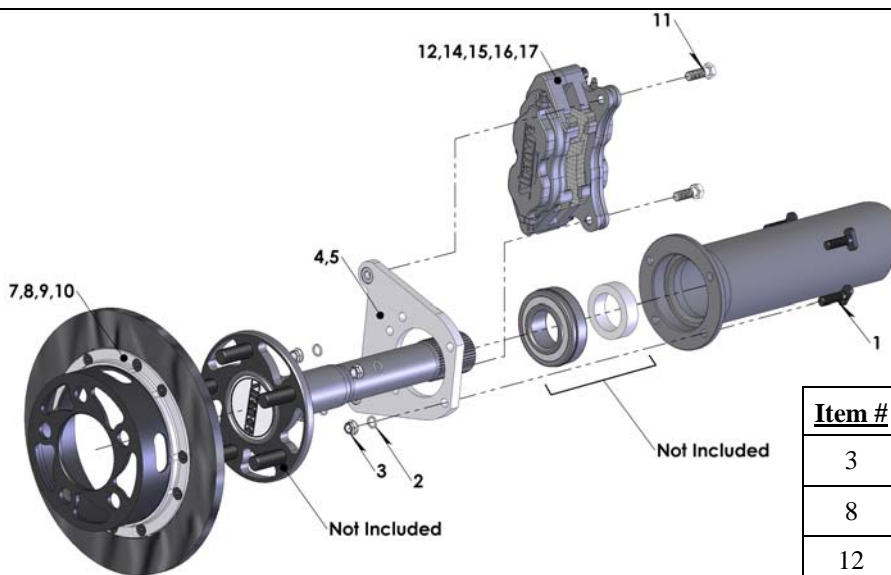

Installation instructions for C18004UC & C18005UC

1. Raise and support rear of vehicle on a level surface using suitable equipment.
2. Remove wheel, axle, and existing brake setup.
3. Remove bearing, wedding ring, and brake bracket/retaining plate.
4. Check the axle for any signs of twisting or run out and repair or replace as needed. The maximum allowable run out checked between centers at the face of the flange, bearing surface, and near the splines is 0.005" total indicated run out (T.I.R.).
5. Inspect the rotor assembly for fit on the axle flange. The rotor adapter (6,7) should slide freely over the axle flange and seat flush against the face of the axle flange. The rotor adapter (6,7) must center on the axle flange or axle studs. If the axle flange is too large, it must be machined to 6.240" diameter.
6. Visually inspect the housing end for straightness and repair as needed.
7. Slide the carbon caliper mounting bracket onto the axle with the press nuts facing **OUTBOARD**.

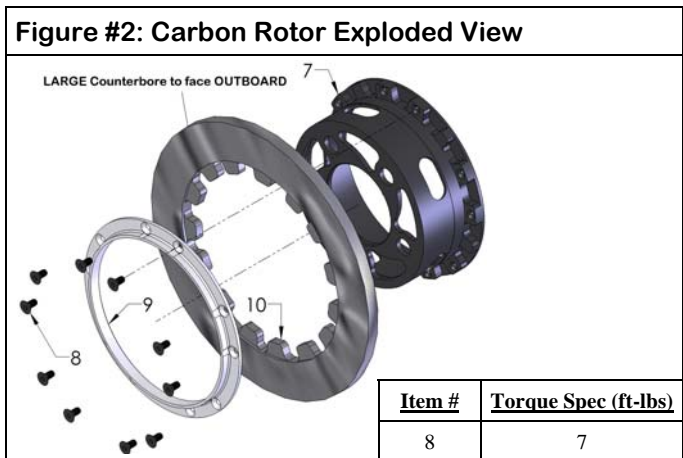

8. Install a new bearing (not included) on the axle, pressing only on the inner race, making sure the seal faces the axle flange. Before installing apply a small amount of oil to the I.D. of the bearing to aid in installation. Make certain that the bearing fully seats against the step on the axle.
9. Press the wedding ring (not included) onto the axle until it seats flush against the bearing.
10. Install the axle into the housing until the bearing bottoms out in the housing end.
11. Engage the caliper mounting bracket over the T-bolts and install using the 3/8-24 "jet" nuts (3) and 3/8" AN washers (2).
Torque to 35 ft-lbs.
Note: The bracket can be oriented towards either the front or rear of the car depending on application and/or desired location.
12. Slide the rotor assembly over the wheel studs and axle flange, ensuring that the rotor sits flat on the face of the axle flange. Rotors come preassembled from Strange Engineering. However, if you ever need to disassemble the rotor, reassemble it by placing the rotor (10) between the retaining ring (9), and the adapter (6,7). Secure using 1/4-20 x 1/2" flat head socket bolts (8) and torque to 15-20 ft-lbs. Re-torque before every event to 15-20 ft-lbs.
Note: During re-assembly of rotor ensure that the large counterbore on the 11" carbon rotor (10) faces **OUTBOARD**; otherwise the retainer ring (9) will not fully seat on the rotor (10) and **FAILURE** will occur. (Refer to figure 2)
-Please read B1860 instructions for complete carbon ultra caliper instructions.
13. Attach caliper (13,14) with the arrow facing in the direction of normal rotor rotation using 3/8"-24 caliper bolts (11). Torque the caliper mounting bolts (11) to 35 ft-lbs.
Note: Calipers are directional and must mount with the arrow pointing in the direction of normal rotation. Refer to B1860 instructions for more caliper information.
14. Connect the brake lines to the calipers. Calipers are tapped to 1/8"-27 NPT and supplied with -3AN fittings. Use proper adapters to connect them to existing lines or use new -3AN braided steel line (teflon lined). Bleed the calipers with DOT 4 or DOT 5.1 brake fluid **ONLY**.

Note: After the initial installation of this kit, ensure that there is adequate clearance between all braking and chassis components by moving the suspension all the way up and down throughout its travel. Additionally, make sure that the brake lines are not subject to binding or kinking. Operate the vehicle in a cautious manner until you determine that the brakes are functioning properly. Check and re-torque all bolts before every event.

Note: Rear Carbon Brakes perform best with caliper pressure from 1,100-1,200 psi

Note: Pads should be replaced when thickness equals .200" or less (thicker heat shields to be used as pads wear). Replace rotors when thickness equals .300" or less. Rotors wear concave and pads wear convex; therefore, measure rotor thickness in the middle of the rotor and pad thickness in the area where there are no pistons.

Note: Keep Carbon away from all chemicals. If contamination occurs the carbon component must be baked for 8 hours @ 500° F-(**Bake Carbon ONLY! REMOVE ALUMINUM HAT & HARDWARE BEFORE BAKING**)- If badly contaminated an odor will occur.

Note: The **HOTTER** the rotors become, the **MORE EFFECTIVE** braking becomes. Carbon brakes will stop your vehicle far better at the "top end" and will not "hold" as well at the starting line, compared to steel brakes. We recommend that when you first drive or "tow" your vehicle to the starting line, you apply the brakes several times to get the "feel" of carbon at low speeds. After you become comfortable with the vehicle at "pit area" speeds, you may want to "drag" the brakes to create rotor and pad heat to better hold the vehicle at the starting line. We recommend a few 1/2 or 3/4 passes, so as to become aware of how your carbon brakes perform at higher M.P.H. Remember carbon works better at higher temperature. The longer the brakes are applied the more aggressive braking will become.

WARNING – RACING IS HAZARDOUS · STRANGE BRAKES ARE FOR LEGAL DRAG RACING ONLY

Disclaimer of Warranty – Purchasers using Strange Engineering racing components and equipment any and all inventory services, purchasers acknowledge that due to differing conditions and circumstances under which all equipment and parts are installed and used, purchasers are not relying on Strange Engineering Co. skill or judgment to select or furnish the proper part or equipment. Purchasers expressly affirm they are relying upon their own skill or judgment to select and purchase suitable goods. Strange Engineering Co. makes no warranties whatsoever, expressed or implied, oral or written, to purchasers. There is no warranty of merchantability made to purchasers. Strange Engineering Co., further excludes any implied warranty of fitness with respect to racing and equipment, any and all inventory and service.