

# Strange

*Engineering*

8300 North Austin Avenue · Morton Grove IL 60053 · 847-663-1701 · Fax 847-663-1702 · www.strangeengineering.net

**Installation instructions for B1150WC & B1150WCM rear steel brake kit for Strange 9" Aluminum Housing dimensioned for Early Oldsmobile brakes.**

**Before you begin installation:** Strange Engineering brake kits are designed for **DRAG RACING ONLY!** Read these instructions thoroughly and save for future reference. If after reading these installation instructions, you have any questions or comments, please do not hesitate to call us.

### KIT CONTENTS

<u>Item#</u>	<u>Part#</u>	<u>Qty.</u>	<u>Description</u>
1	B2792	1	HD Right-hand rotor
2	B2793	1	HD Left-hand rotor
3	B1737B	8	3/8-24 x 1 1/4" HHCS Bolt
4	S3402N	8	3/8" AN Washer
5	B1700A	2	Early Olds Caliper Mount
6	B1301E	4	3/8-24 Press Nut (Installed in B1158A)
7	B1301H	16	0.025" Thick caliper shim
8	B1301J	4	1/16" Thick caliper washer
9	B5000Y	4	3/8"-24 x 1-1/8" Caliper bolt
10	B5010	4	Soft 4-piston brake pad (B1150WC)
11*	B5020	4	Hard metallic 4-piston brake pad (B1150WCM)
12	B5002	1	Right-hand 4 piston caliper
13	B5004	1	Left-hand 4 piston caliper
14	P2316	2	1/8" NPT x -3AN Fitting (Installed in B5002 & B5004)
15	P2316C	2	Plastic Cap for -3AN Fitting (Installed in B5002 & B5004)

\*Replaces soft pad (10) for B1150WCM

<u>Item #</u>	<u>Torque Spec (ft-lbs)</u>
3	40
9	35

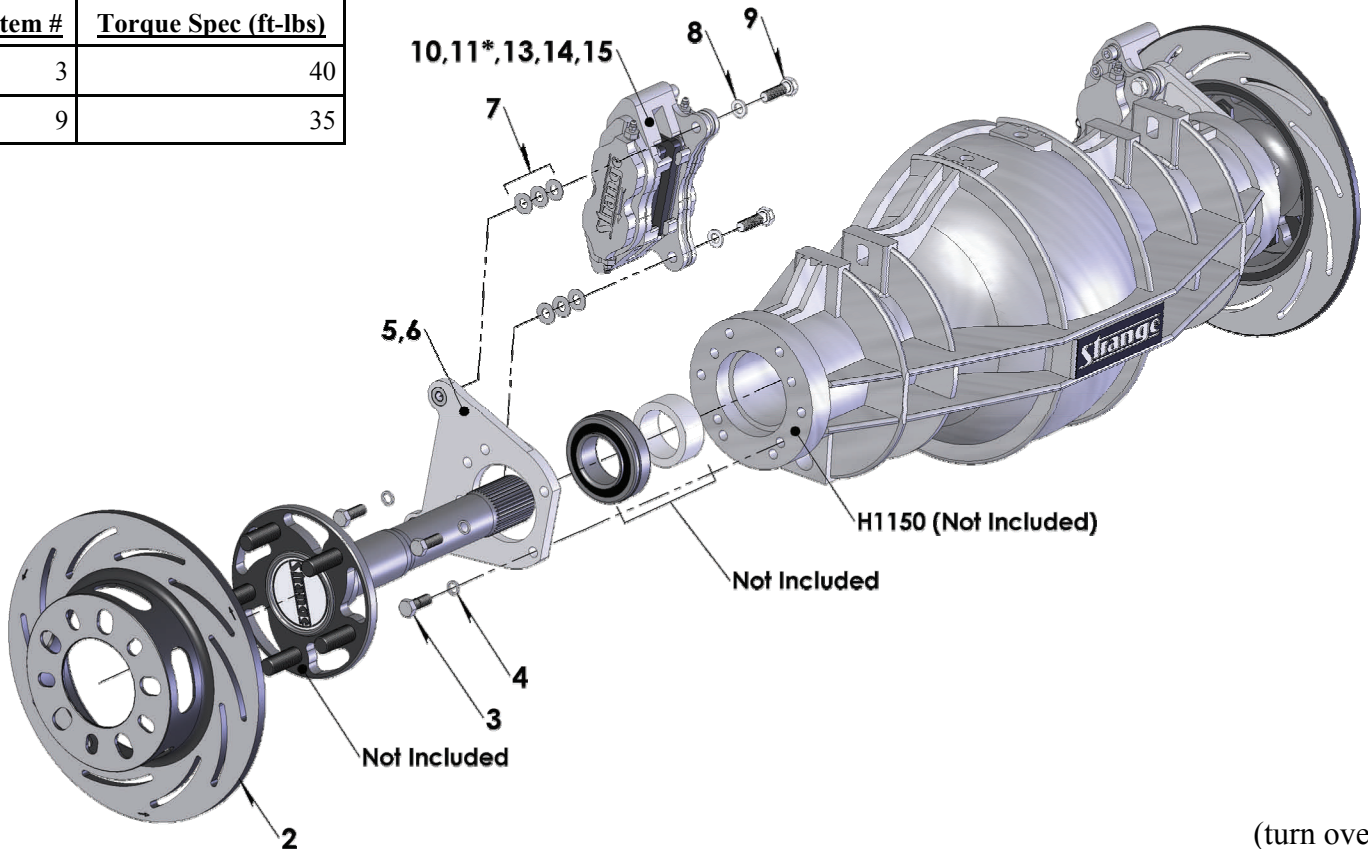

(turn over)

**Figure #1:** Driver's Side Assembly Shown

# Installation Instructions

- 1.) Raise and support rear of vehicle on a level surface using suitable equipment.
- 2.) Slide the caliper mounting bracket (5) on the axle.  
*Note:* Ensure that press nuts (6) are facing **OUTBOARD**. (See figure 3)
- 3.) Install a new bearing on the axle, pressing only on the inner race making sure the seal faces the axle flange. Before installing, apply a small amount of oil to the I.D. of the bearing to aid in installation. Make certain that the bearing fully seats against the step on the axle.
- 4.) Press the wedding ring onto the axle until it seats flush against the bearing.
- 5.) Install the axle into the housing until the bearing bottoms out in the housing end.
- 6.) Install the caliper mounting bracket (5) using the 3/8-24 x 1-1/4" HHCS bolts (3) and 3/8" AN washers (4). Torque to 40 ft-lbs.  
*Note:* Caliper bracket can be mounted facing either the front or the rear depending on desired orientation and/or application.
- 7.) Slide the rotor (1,2) over the wheel studs and axle flange, ensuring that the rotor sits flat on the face of the axle flange.  
*Note:* Slotted rotors mount with the arrow pointing in the direction of normal rotation (See Figure 2).

**Figure 2:** Driver's Side Shown  
Rotors AND Calipers are  
**DIRECTIONAL**

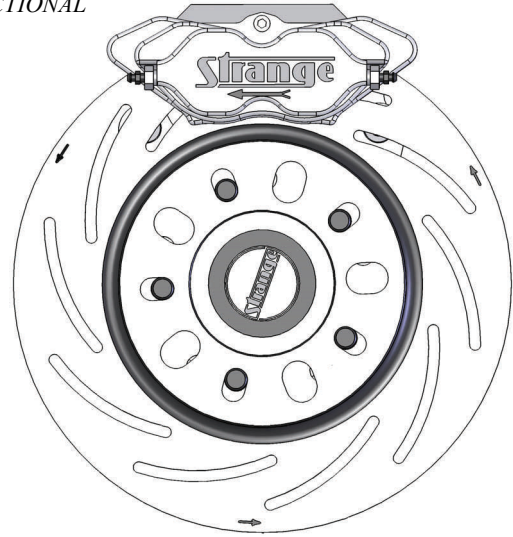

- Please read **B1850 instructions for complete caliper instructions if using soft pads. (B1150WC)**

- Please read **B1855 instructions for complete caliper instructions if using hard metallic pads. (B1150WCM)**

- 8.) Attach caliper (12,13) with the arrow facing in the direction of normal rotor rotation using 3/8"-24 caliper bolts (9) and 1/16" thick flat washers (8). Use 0.025" thick caliper shims (7) to center the caliper over the rotor, making sure pads contact the rotor evenly. The caliper bolt (9) should be fully engaged into the press nut. If the bolt is over engaged, use any remaining shims under the head of the bolt to prevent it from running into the rotor. Torque the caliper mounting bolts (9) to 35 ft-lbs.
- 9.) Connect the brake lines to the calipers. Calipers are tapped to 1/8"-27 NPT and supplied with -3AN fittings. Use proper adapters to connect them to existing lines or use new -3AN braided steel line (teflon lined). Bleed the calipers with DOT 4 or DOT 5.1 brake fluid **ONLY**.
- 10.) A proper break in procedure is required to avoid brake fade and uneven rotor deposits from the pads. It consists of 8-10 brake applications increasing in harshness while allowing the brakes to cool slightly in between; do not keep the brakes applied between stops. After the last stop the brakes should be allowed to cool completely.

**Figure 3:** View From Rear

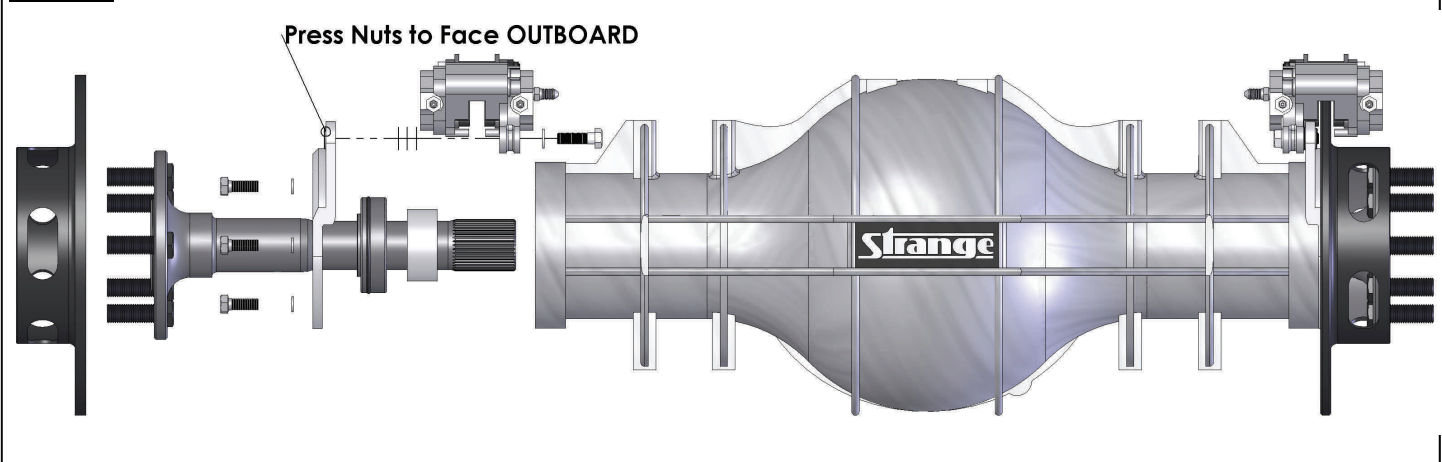

**Note:** After the initial installation of this kit, ensure that there is adequate clearance between all braking and chassis components by moving the suspension all the way up and down throughout its travel. Additionally, make sure that the brake lines are not interfering with the wheel travel, or subject to binding or kinking. Operate the vehicle in a cautious manner until you determine that the brakes are functioning properly. Routinely check and re-torque all bolts.

## **WARNING – RACING IS HAZARDOUS · STRANGE BRAKES ARE FOR LEGAL DRAG RACING ONLY**

**Disclaimer of Warranty –** Purchasers using Strange Engineering racing components and equipment any and all inventory services, purchasers acknowledge that due to differing conditions and circumstances under which all equipment and parts are installed and used, purchasers are not relying on Strange Engineering Co. skill or judgment to select or furnish the proper part or equipment. Purchasers expressly affirm they are relying upon their own skill or judgment to select and purchase suitable goods.

Strange Engineering Co. makes no warranties whatsoever, expressed or implied, oral or written, to purchasers. There is no warranty of merchantability made to purchasers. Strange Engineering Co., further excludes any implied warranty of fitness with respect to racing and equipment, any and all inventory and service.