

# Strange

*Engineering*

8300 North Austin Avenue · Morton Grove IL 60053 · 847-663-1701 · Fax 847-663-1702 · www.strangeengineering.net

**Installation instructions for B4453WC (4.5" B.C.) and B4454WC (4.75" B.C.) medium duty front brake kit for '87 to present Strange Forged Aluminum Struts (also see Strange Strut Instructions.)**

**Before you begin installation:** Strange Engineering brake kits are designed for **DRAG RACING ONLY!** Read these instructions thoroughly and save for future reference. If after reading these installation instructions, you have any questions or comments, please do not hesitate to call us. This brake kit has been designed to the 1987 to present Strange Engineering strut spindle. Do not attempt to fit this kit to earlier design Strange Struts.

## KIT CONTENTS

<u>Item#</u>	<u>Part#</u>	<u>Qty.</u>	<u>Description</u>
1	A1028A	10	1/2"-20 x 2.5" Wheel stud
2	A1028B	10	1/2" I.D. Wheel stud washer
3	B1301E	4	3/8"-24 Press nut (Installed in B4454A/B)
4	B1320H	2	Inner hub bearing cup (Timken LM67010 installed in B4154C/SP)
5	B1320J	2	Inner hub bearing cone (Timken LM67048)
6	B4154C	2	Aluminum Hub "H" (4.75" B.C.) -B4454WC Kit
-	B4154SP	2	Aluminum Hub (4.50" B.C.) -B4453WC Kit
7	B1324D	2	Outer hub bearing cup (Timken LM11910 installed in B4154C/SP)
8	B1324E	2	Outer hub bearing cone (Timken LM11949)
9	S3402Q	4	3/8"-24 caliper bracket bolt
10	B2795	1	Right hand HD/MD tapered rotor
11	B2796	1	Left hand HD/MD tapered rotor
12	B1301H	16	3/8" I.D. x 0.025" Thick caliper shim
13	B1301J	4	3/8" I.D. x 1/16" Thick flat washer
14	B5000Y	4	3/8"-24 x 1.125" Caliper bolt
15	B2510	4	Soft 2-piston caliper pad
16	B2560	2	2-piston caliper
17	P2316	2	1/8" NPT x -3AN Fitting (Installed in B2560)
18	B4154E	2	Aluminum hub cap
19	B4454B	1	Caliper mount bracket (Drivers side)
20	B4454A	1	Caliper mounting bracket (Passengers side)
21	S3402N	4	3/8" washer
22	F1282	4	3/8"-24 locknut
23	S3520F	2	#222 Buna O-ring (Installed on B4154E)
24	B1328B	2	Hub seal (National 6815)

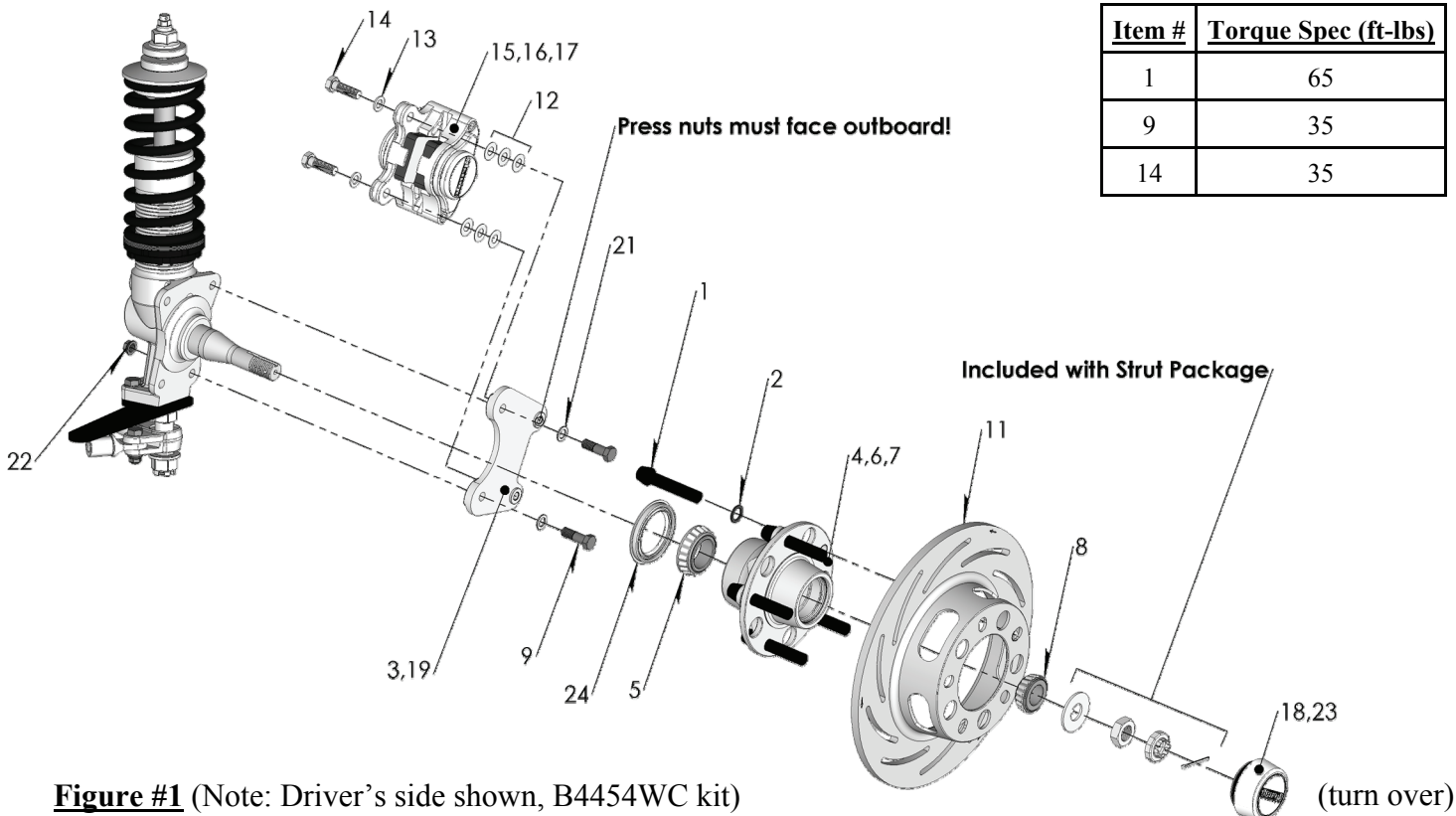

**Figure #1** (Note: Driver's side shown, B4454WC kit)

## Installation Instructions

- 1.) Raise and support front of vehicle on a level surface using suitable equipment.
- 2.) Remove wheel, caliper, rotor, hub, and brake line. Inspect all spherical bearings and rod ends for excessive play and replace as needed.
- 3.) Install the caliper mount (19,20) using the 3/8" caliper bracket bolts (9), 3/8" washers (21), and 3/8" locknuts (22) making sure the press nuts (3) are facing towards the rotor (10, 11). Torque to 35 ft.-lbs.
- 4.) Install 1/2" Dia. wheel studs (1) in front hub (6) using 1/2" I.D. wheel stud washer (2) and a small amount of BLUE Loc-tite®. Torque all studs to 65 ft.-lbs. *Note:* Consult your wheel and/or lug nut manufacturer for proper lug nut torque.
- 5.) Pack inner (5) and outboard bearing cone (8) with NLGI 1 wheel bearing grease. *Note:* A bearing packer is recommended for this procedure; If one is not available work as much grease as possible into the cage and around the rollers.
- 6.) Wipe a thin layer of wheel bearing grease on the bearing surface of the inner and outer cups (4, 7) and then place inner bearing cone (5) into the front hub (6).
- 7.) Press the hub seal (24) into the inboard side of the hub (6) flush to the outer face of the hub.
- 8.) Slide the hub assembly onto the spindle then slide the outer bearing cone (8) over the spindle and into the hub (6).
- 9.) Install the key washer and the spindle nut (included in strut package).
- 10.) Mount the wheel and tire assembly on the hub and snug the lug nuts.
- 11.) While rotating the wheel, torque the spindle nut to approximately 20 ft.-lbs. Then, loosen the spindle nut until the wheel spins freely and there is no end play.
- 12.) Install the stamped spindle nut retainer, cotter pin, aluminum hub cap (18), and remove the wheel and tire.
- 13.) Slide the rotor (10, 11) over the wheel studs flush to the face of the hub (6). *Note:* Slotted rotors mount with the arrow pointing in the direction of normal rotation (See Figure #2).

- Please read B1825 instructions for complete caliper instructions.

- 14.) Attach caliper (16) using 3/8"-24 caliper bolts (14) and 3/8" I.D. washers (13). Use 3/8" I.D. caliper shims (12) to center the caliper over the rotor, making sure pads contact the rotor evenly. The caliper bolt (14) should be fully engaged into the press nut. If the bolt is over engaged, use any remaining shims under the head of the bolt to prevent it from running into the rotor. Torque the caliper mounting bolts (14) to 35 ft.-lbs.
- 15.) Connect the brake lines to the calipers. Calipers are tapped to 1/8"-27 NPT and supplied with -3AN fittings. Use proper adapters to connect them to existing lines or use new -3AN braided steel line (teflon lined). Bleed the calipers with DOT 4 or DOT 5.1 brake fluid **ONLY**.
- 16.) A proper break in procedure is required to avoid brake fade and uneven rotor deposits from the pads. It consists of 8-10 brake applications increasing in harshness while allowing the brakes to cool slightly in between; do not keep the brakes applied between stops. After the last stop the brakes should be allowed to cool completely.

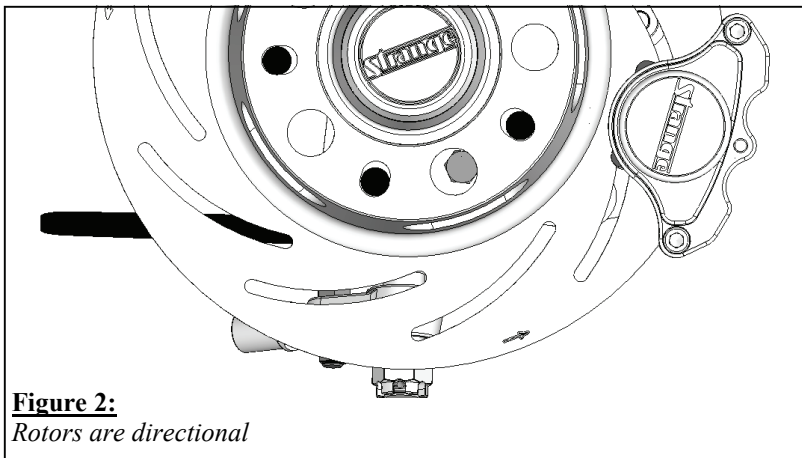

**Figure 2:**  
*Rotors are directional*

**Note:** After the initial installation of this kit, ensure that there is adequate clearance between all braking and chassis components by turning the wheels all the way left to right and moving them all the way up and down throughout the length of the wheel (suspension) travel. Additionally, make sure that the brake lines are not interfering with the wheel travel, or subject to binding or kinking. Operate the vehicle in a cautious manner until you determine that the brakes are functioning properly. Routinely check and re-torque all bolts.

### **WARNING – RACING IS HAZARDOUS · STRANGE BRAKES ARE FOR LEGAL DRAG RACING ONLY**

**Disclaimer of Warranty –** Purchasers using Strange Engineering racing components and equipment any and all inventory services, purchasers acknowledge that due to differing conditions and circumstances under which all equipment and parts are installed and used, purchasers are not relying on Strange Engineering Co. skill or judgment to select or furnish the proper part or equipment. Purchasers expressly affirm they are relying upon their own skill or judgment to select and purchase suitable goods. Strange Engineering Co. makes no warranties whatsoever, expressed or implied, oral or written, to purchasers. There is no warranty of merchantability made to purchasers. Strange Engineering Co., further excludes any implied warranty of fitness with respect to racing and equipment, any and all inventory and service.

