

Installation instructions for C4694WC Carbon Rotor (11") Front Brake Kit for Strange Adjustable Height Spindle

Important Notes:

- Kit is designed for 2009 and later Strange Adjustable Height Spindles (S3423) and is for one piece wheels only.
- Strange Engineering brake kits are designed for **DRAG RACING ONLY!**
- Carbon brake pads (B1250P) minimal thickness is 0.200".
- 11" Carbon rotors (C1790) minimal thickness is 0.300".
- Also consult Strange Adjustable Height Spindle Install Instructions

Before you begin installation:

Read these instructions thoroughly and save for future reference.

If after reading these installation instructions, you have any questions or comments, please do not hesitate to call us.

KIT CONTENTS			
Item#	Part#	Qty.	Description
1	C1790	2	Carbon Rotor 11"
2	S3402N	26	3/8" AN Washer
3	F1282	18	3/8"-24 Jet Nut
4	B5000Z	4	3/8"-24 x 1.187" Bolt
5	B4694A	2	Caliper Mounting Bracket
6	B1260AW	2	Caliper Outer Half
7	C4596B	2	1/4"-28 x .500 Thread Insert
8	H1150E	4	3/8"-24 x .520" Thread Insert
9	B1250P	4	Carbon Brake Pad
10	B1260DZ	2	Outboard "Hotdog" Bracket
11	B1250H	4	Garlock 08-DU06 Bearing (installed in B1260DZ)
12	B1264J	2	Bridge Bolt Tube
13	B5000P1	2	Caliper Piston
14	B1260BY	2	Caliper Inner Half
15	B5000V	2	Caliper Piston O-Ring (installed in B1260BY)
16	B1260BU	2	3/8" x 9/16" Caliper Piston Dowel Pin O-Ring (installed in B1260BY)
17	P2316	2	1/8" x #3AN NPT Fitting
18	B1260BV	2	Piston Dowel Pin
19	P2365F	2	1/8" NPT Bleeder Assembly
20	L4000O	2	1/8" NPT Socket Plug
21	B3311C	4	Caliper Slide Pin
22	B1260CW	2	Inboard "Hotdog" Bracket
23	B1260K	4	Garlock 05-DU06 Bearing (installed in B1260CW)
24	C4596D	4	3/8"-24 x 3-1/4" Caliper Bolt
25	B1260E	2	1/4" Washer
26	C4596E	2	1/4"-28 x 3-1/4" Caliper Bridge Bolt
27	C1700D	20	1/4"-20 x 1/2" Flat-Head Socket Cap Screw
28	C1700H	2	Carbon Rotor Retainer Ring
29	B1250SC	2	Carbon Rotor Adapter

Figure #1: Assembly shown with 2009 and later S3423 Strange Adjustable Height Spindle

(see figure 2.1)

NOTE: Caliper can be mounted either forward or rearward position on the spindle body. Ensure bleeder assembly is always installed in the highest portion of the caliper.

Item #	Torque Spec (ft-lbs)
3	35

Figure #2.1: Brake Caliper Mounted Driver Side Towards Rear / Passenger Side Towards Front

Item #	Torque Spec (ft-lbs)
3	35
24	25-30
26	8-10

Figure #2.2: Brake Caliper Mounted Driver Side Towards Front / Passenger Side Towards Rear

Item #	Torque Spec (ft-lbs)
3	35
24	25-30
26	8-10

Installation instructions for C4694WC

1. Rotors come preassembled from Strange Engineering. However, if rotor disassembly is ever required unscrew the ten flathead socket cap screws (27) and separate the rotor (1) from the rotor retainer ring (28) and rotor adapter (29). Reassemble rotor vise-versa **ensuring the larger counter bore of the rotor (1) faces outboard** and torque the ten flathead socket cap screws (27) to 45-50 in-lbs. (Figure #3) Re-torque before every event.
2. Mount the rotor on the wheel using 3/8" studs supplied with the wheel and the 3/8" washers (2) and jet nuts (3) supplied with this brake kit. Torque to approximately 35 ft-lbs. (Figure #1)
3. Disassemble brake caliper by removing the caliper bolts (24) and the caliper bridge bolt (26). The slide pins (21) should remain attached to the caliper mounting bracket (5). (Figure #2)
4. Attach the caliper mounting bracket (5) with the slide pins (21) to the spindle body using the two 3/8"-24 bolts (4), 3/8" washers (2) and jet nuts (3). Torque (3) to 35 ft-lbs. The threads of the slide pins (21) always face inboard. The mounting bracket can be installed multiple ways depending on whether the caliper is intended for installation towards the front or rear of the vehicle.
5. Follow the spindle kit instructions to assemble the wheel onto the spindle.
6. Slide the two caliper bolts (24) with the 3/8" washers (2) and the caliper bridge bolt (26) with a 1/4" washer (25) through their respective holes on the inboard "hotdog" bracket (22). (Figure #2)
7. The caliper must now be assembled onto the caliper bracket (5). Slide the inboard "hotdog" bracket (22) with the two caliper bolts (24) and the caliper bridge bolt (26) onto the inboard side of the caliper slide pins (21). The threads on the bolts should face outboard towards the wheel. (Figure #2)
8. Feed the caliper inner half (14) over the rotor or through the outside of the wheel and slide through the two caliper bolts (24) and the caliper bridge bolt (26). (Figure #2) **Ensure bleeder assembly (19) is always installed in the highest portion of the caliper.**
9. Slide the carbon brake pad (9) and caliper bridge bolt tube (12) through the caliper bridge bolt (26). (Figure #2)
10. Slide the outboard "hotdog" bracket (10) through the two caliper slide pins (21), caliper bolts (24) and caliper bridge bolt (26). **Ensure the counter bore on the outboard "hotdog" bracket (10) faces outboard.**
11. Align a carbon brake pad (9) with the caliper outer half (6). Finally, line up caliper outer half (6) and carbon brake pad (9) with the two caliper bolts (24) and the caliper bridge bolt (26). Loosely secure the two caliper bolts (24) and caliper bridge bolt (26) as the caliper outer half (6) is attached. Ensure the entire assembly corresponds to figure #2. Torque caliper bolts (24) to 25-30 ft-lbs and the bridge bolt (26) to 8-10 ft-lbs.
12. Connect the hydraulic lines to the calipers. Calipers are tapped to 1/8"-27 NPT and supplied with -3AN fitting. Connect them to existing lines or use new -3AN braided steel line (Teflon lines). Bleed calipers with DOT 4 or DOT 5.1 brake fluid only!

Figure #3: Carbon Rotor Exploded View

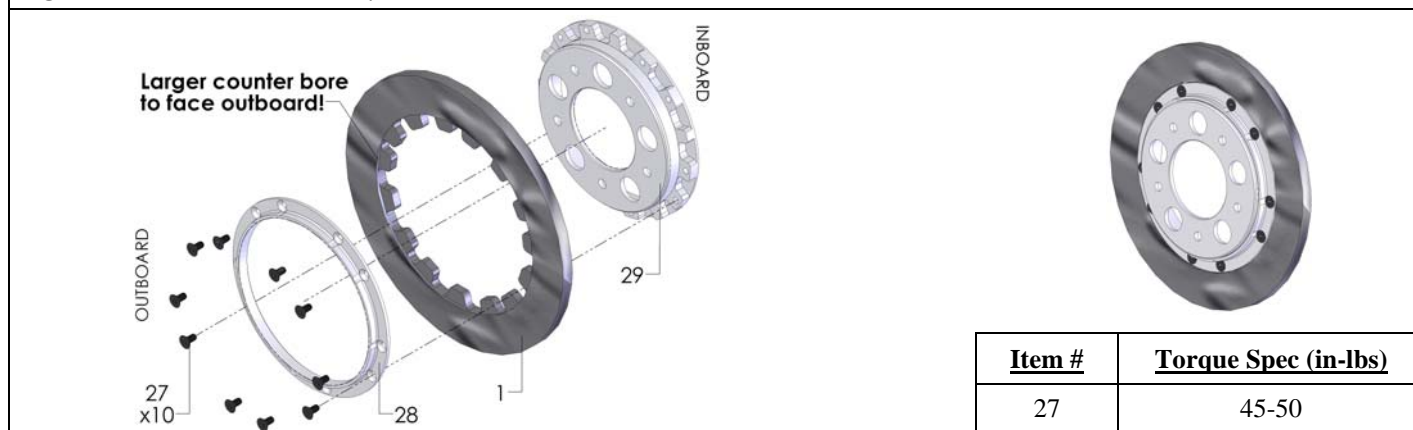

Note: After the initial installation of this kit, ensure that there is adequate clearance between all braking and chassis components by moving the suspension all the way up and down throughout its travel. Additionally, make sure that the brake lines are not subject to binding or kinking. Operate the vehicle in a cautious manner until you determine that the brakes are functioning properly. Check and re-torque all bolts before every event.

Note: Pads should be replaced when thickness equals .200" or less. Replace rotors when thickness equals .300" or less. Rotors wear concave and pads wear convex; therefore, measure rotor thickness in the middle of the rotor and pad thickness in the area where there are no pistons.

Note: Keep Carbon away from all chemicals. If contamination occurs the carbon component must be baked for 8 hours @ 500° F-(**Bake Carbon ONLY!** REMOVE ALUMINUM HAT & HARDWARE **BEFORE BAKING**)- If badly contaminated an odor will occur.

Note: The **HOTTER** the rotors become, the **MORE EFFECTIVE** braking becomes. Carbon brakes will stop your vehicle far better at the "top end" and will not "hold" as well at the starting line, compared to steel brakes. We recommend that when you first drive or "tow" your vehicle to the starting line, you apply the brakes several times to get the "feel" of carbon at low speeds. After you become comfortable with the vehicle at "pit area" speeds, you may want to "drag" the brakes to create rotor and pad heat to better hold the vehicle at the starting line. We recommend a few 1/2 or 3/4 passes, so as to become aware of how your carbon brakes perform at higher M.P.H. Remember carbon works better at higher temperature. The longer the brakes are applied the more aggressive braking will become.

WARNING – RACING IS HAZARDOUS · STRANGE BRAKES ARE FOR LEGAL DRAG RACING ONLY

Disclaimer of Warranty – Purchasers using Strange Engineering racing components and equipment any and all inventory services, purchasers acknowledge that due to differing conditions and circumstances under which all equipment and parts are installed and used, purchasers are not relying on Strange Engineering Co. skill or judgment to select or furnish the proper part or equipment. Purchasers expressly affirm they are relying upon their own skill or judgment to select and purchase suitable goods. Strange Engineering Co. makes no warranties whatsoever, expressed or implied, oral or written, to purchasers. There is no warranty of merchantability made to purchasers. Strange Engineering Co., further excludes any implied warranty of fitness with respect to racing and equipment, any and all inventory and service.