



**STRANGE 4 PISTON  
DIRECTIONAL CALIPERS**

**CALIPER KIT #**  
**B1850** Semi-Metallic Pads  
**B1855** Metallic Pads

Installation to be performed by a qualified technician.

**Important Notes**

- Metallic & semi-metallic brake pads have 0.200" minimum thickness.
- 11.25" Steel rotors (B2792, B2793, B2795 & B2796) have 0.312" minimum thickness
- Strange Four Piston Directional Caliper o-ring rebuild kit is available under part # B5109 (sold per caliper).  
**Note:** This instruction sheet overviews installation of the caliper. A separate caliper rebuild guide is available.
- The arrow on the calipers and rotors must face the direction of normal rotation of the rotor/wheel.
- Perform proper brake pad and rotor bed-in procedure outlined on page 3 to maximize brake performance.
- See page 3 & 4 of instructions for brake pad guide, Strange accessories and brake fluid comparison.

**Before you begin installation**

Strange Engineering calipers are designed for DRAG RACING ONLY!  
 Wheel offset with Strange Engineering brakes can be calculated using the guidelines on page 4.  
 Brake rotors are shipped with an oil film on surface to prevent rust and must be cleaned before installation.  
 Read these instructions thoroughly and save for future reference.  
 If after reading these installation instructions, you have any questions or comments, please do not hesitate to call us.

**Features & Technical Information**

- Billet Aluminum
- Internal Fluid Crossover Ports
- Staggered Piston Bore Sizes  
*Smaller piston is closest to rotor entrance. Larger piston provides a greater clamping force at the trailing edge of the pad reducing pad taper or deflection.*
- Compact & Lightweight CNC Design
- 4 Accessible Two-Piece Bleed Screws

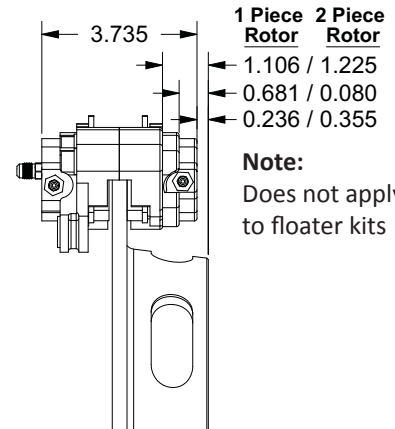
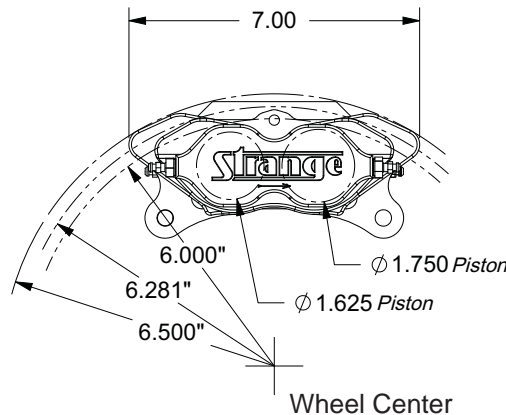

CALIPER KIT CONTENTS			
ITEM#	PART#	QTY	DESCRIPTION
1	B5010	4	Semi-metallic Brake Pads <i>(only with B1850)</i>
2	B5020	4	Metallic Brake Pads <i>(only with B1855)</i>
3	B5000Y	4	3/8-24 x 1.125" Caliper Mounting Bolt
4	B1301J	4	Caliper Bolt Washer
5	B1301H	16	3/8" ID x 0.025 Thick Caliper Shim
6	—	2	1/4"-20 x 2.625 Bridge Bolt
7	—	2	Bridge Bolt Tube
8	—	2	1/4"-20 Bridge Bolt Nut
—	B5002	1	Passenger Side Brake Caliper
—	B5004	1	Driver Side Brake Caliper

**WARNING – RACING IS HAZARDOUS · STRANGE BRAKES ARE FOR LEGAL DRAG RACING ONLY**

*Disclaimer of Warranty – Purchasers using Strange Engineering racing components and equipment any and all inventory services, purchasers acknowledge that due to differing conditions and circumstances under which all equipment and parts are installed and used, purchasers are not relying on Strange Engineering Co. skill or judgment to select or furnish the proper part or equipment. Purchasers expressly affirm they are relying upon their own skill or judgment to select and purchase suitable goods. Strange Engineering Co. makes no warranties whatsoever, expressed or implied, oral or written, to purchasers. There is no warranty of merchantability made to purchasers. Strange Engineering Co., further excludes any implied warranty of fitness with respect to racing and equipment, any and all inventory and service.*

**STRANGE 4 PISTON  
DIRECTIONAL CALIPERS**

**CALIPER KIT #**  
**B1850** Semi-Metallic Pads  
**B1855** Metallic Pads

Installation to be performed by a qualified technician.

**FIGURE # 1: Caliper Mounting & Brake Pad Installation**

**FIGURE # 2: Center Rotor & Caliper**

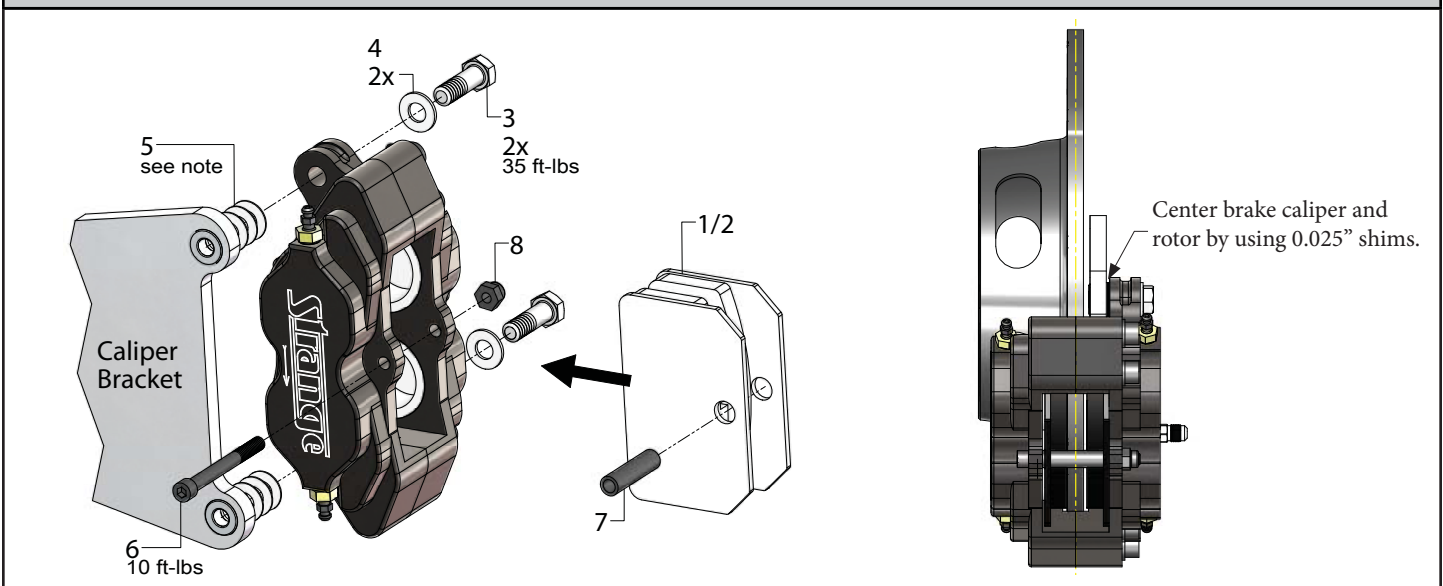

**FIGURE # 3: Brake Rotor & Caliper Orientation**

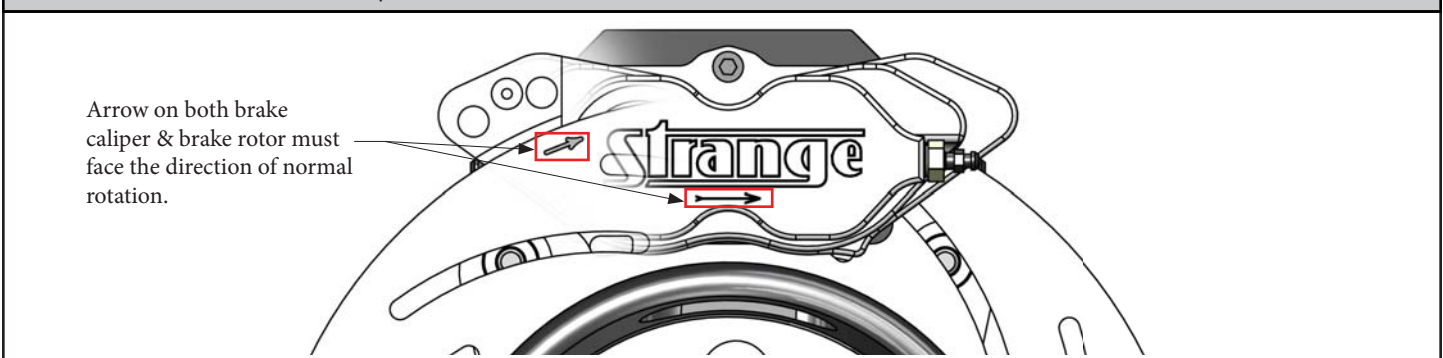

**Installation Instructions:**

1. Mount the caliper onto the caliper bracket using the caliper mounting bolts (3) provided with washer (4) and caliper shims (5).  
**Notes:** Determine proper amount of shims (5) by positioning the caliper as close as possible to the center of the rotor. (see figure #2)  
 The arrows on the caliper and brake rotor must face the direction of normal rotation of the rotor/wheel. (see figure #3)  
 Torque mounting bolts 35ft-lbs.
2. Unscrew the caliper bridge bolt (6) and slide the bridge bolt and bridge bolt tube (7) out of the assembly.
3. Slide the bridge bolt tube (7) through the brake pads (1/2) then slide the assembly into the caliper as shown in figure# 1.
4. Align bridge bolt (6) with the bridge bolt tube (7) and begin to screw in by hand. Torque bridge bolt to 10 ft-lbs.
5. Install the brake lines. The inlet on the inboard half of the caliper is tapped for a 1/8"-27 NPT x -3AN fitting.
6. Bleed the brake caliper. Use DOT 4 or 5.1 brake fluid ONLY.  
**Notes:** Refer to page 3 for additional information on bleeding the brake caliper.  
 Refer to page 4 for additional information on brake fluids.
7. After initial installation of this caliper kit, ensure that there is adequate clearance between all braking and chassis components by moving the wheels all the way up and down throughout the length of their travel. Additionally, make sure that the brake lines are not interfering with the wheel travel or subject to binding or kinking. Operate the vehicle in a cautious manner until you determine that the brakes are functioning properly. Periodically check and re-torque all bolts.

# STRANGE 4 PISTON DIRECTIONAL CALIPERS

Installation to be performed by a qualified technician.

CALIPER KIT #

B1850 Semi-Metallic Pads

B1855 Metallic Pads

Semi-Metallic Brake Pad

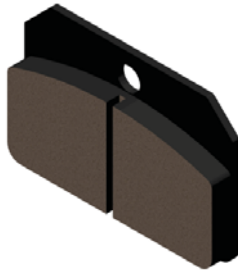

- Recommended for all front applications
- Slot design allows brake dust to escape.
- Used in rear if vehicle does not exceed 150 MPH in the 1/4 mile
- Aggressive initial bite for vehicles requiring rear holding capability to load torque converters or turbochargers.

Metallic Brake Pad



- Used in rear if vehicle exceeds 150 MPH in 1/4 mile
- More aggressive than semi-metallic at operating temperatures
- Greater braking capacity
- Does not fade at higher temperatures.

### Caliper Bleeding by Manual Pumping

1. Connect one end of a plastic hose to the bleeder valve and submerge the other end in a container of brake fluid.
2. The brake pedal must be depressed and held to the floor by one person while another person opens the bleed screw about 1/4 of a turn to allow for the accumulated air and fluid to evacuate.
3. Immediately close the bleeder valve once the fluid has stopped flowing,
4. Pump the brake pedal to refill the master cylinder. Repeat this procedure with all calipers until a firm pedal is achieved.

**⚠ Notes:** Caliper must be positioned vertically so the arrow on the caliper is pointing straight up. Achieve this by temporarily rotating the caliper bracket. It is not necessary to bleed using all bleed screws. Only the highest bleed screws on each side of the caliper needs to be bled. Ensure master cylinder reservoir does not empty!

### Brake Pad and Rotor Bed-In Procedure

A proper bed-in procedure is required for steel brakes to avoid premature brake fade. Bedding the brake pads in prevents uneven pad contact that would otherwise groove the rotors. Ensure pedal is firm and there are no leaks in the system before proceeding with the bed-in procedure. During this procedure, do not drag the brakes. Also, do not stop the vehicle completely.

1. Using moderate pressure make 6-10 stops from 35 mph to 10 mph. Allow 30 seconds for brakes to cool in-between stops.
2. Increase speed to about 50 mph and perform 3 hard stops to 10 mph. Allow 30 seconds for brakes to cool in-between stops.
3. Wait 15 minutes for the brake system to cool down.

### Troubleshooting

- |  |   |
|--|---|
| <ul style="list-style-type: none"> <li>•Hard pedal, but not enough brake pressure<br/><i>Pedal ratio too small</i><br/><i>Master cylinder bore too large</i></li> <li>•Brake Drag<br/><i>Master cylinder piston not fully retracting</i><br/><i>Calipers not square to rotors</i><br/><i>Incorrect residual pressure valve</i></li> <li>•Pulsating Pedal<br/><i>Warped rotors</i><br/><i>Rotor faces not parallel</i><br/><i>Excessive play in wheel bearings</i></li> </ul> | <ul style="list-style-type: none"> <li>•Soft or spongy pedal<br/><i>Insufficient fluid volume (master cylinder bore too small or not enough stroke)</i><br/><i>Old brake fluid (conditions worsen as temperature increases)</i><br/><i>Air in brake system</i><br/><i>Calipers not square to rotor</i><br/><i>Pedal ratio too high</i><br/><i>Too much flex line in system (braided stainless or rubber)</i><br/><i>DOT 5 (silicone) fluid in system</i></li> </ul> |
|--|---|

**STRANGE 4 PISTON  
DIRECTIONAL CALIPERS**

**CALIPER KIT #**  
**B1850** Semi-Metallic Pads  
**B1855** Metallic Pads

Installation to be performed by a qualified technician.

**Brake Fluid Breakdown**

- Due to temperatures experienced during drag racing, DOT 4, DOT 5.1 or a high performance glycol based brake fluid is recommended.
- Brake systems are prone to moisture from humidity and regular use, therefore, moisture must be absorbed by the brake fluid instead of collected so the fluid does not easily boil. When moisture enters the system, it settles at the lowest point in which most cases is the caliper. At braking temperatures moisture can boil causing a loss or lack of pedal/handle.
- DOT 5 (silicone based) is not recommended. It does not mix with other fluids. It is slightly compressible giving soft pedal/handle. It also does not absorb water.
- Always perform a complete flush to the brake system when changing to a different brake fluid to avoid contamination.
- Do not use brake fluid from open bottles or bottles stored for long periods as moisture may have been absorbed.
- The dry boiling point is the temperature at which brake fluid will boil with no water (moisture) present in the system.
- The wet boiling point is the temperature at which brake fluid will boil when 3% is water by volume of the system.
- In race applications it's assumed brake fluid is changed often therefore moisture is not present and the dry boiling point can be a better reference when deciding on which fluid to use.

	Dry Boiling Point °F	Wet Boiling Point °F
<b>DOT 3</b> ↻ Inexpensive, readily available, mixes with DOT 4 and DOT 5.1 ↻ Lowest boiling point, absorbs water, eats paint	<b>400</b>	<b>285</b>
<b>DOT 4</b> ↻ Higher boiling point than DOT 3, absorbs water less readily than DOT 3 ↻ Absorbs water, eats paint	<b>445</b>	<b>310</b>
<b>DOT 5</b> ↻ Does not eat paint, high boiling point ↻ Does not mix with water, difficult to bleed	<b>500</b>	<b>355</b>
<b>DOT 5.1</b> ↻ High boiling point, mixes with DOT 3 & 4 ↻ Absorbs water, eats paint	<b>527</b>	<b>365</b>

**Calculating Front Wheel Position**

The following method applies to most front Strange brake kits with Strange hubs.

A) Measure the distance from the **caliper bracket mounting surface** which the Strange Engineering caliper bracket will mount on to the **face of the factory hub** to which the wheel mounts on.

Record this measurement: \_\_\_\_\_

B) Subtract 2.835" from the distance above to calculate the change in wheel position compared to the factory setup.

Wheel position: \_\_\_\_\_

**Note:** A positive value in wheel position means wheel is moved inboard.  
 A negative value in wheel position means wheel is moved outboard.  
 If wheel spacer is used must add thickness of spacer to 2.835"

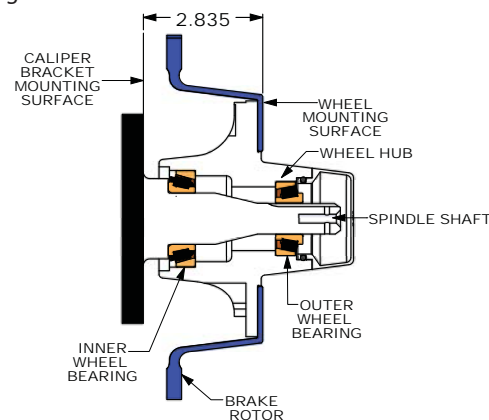

**Additional Strange Accessories** see pg. 111 & 112 of catalog

- |   |  |
|---|--|
| P2360 Brake Pressure Gauge:                                   | Accurately measure brake line pressure                     |
| B3366 External pressure (residual) valve male/female (2lbs):  | Installed when master cylinders are mounted below calipers |
| B3367 External pressure (residual) valve male/female (10lbs): | Installed when using drum brakes                           |
| B3369 Adjustable proportioning valve:                         | Used to adjust front to rear braking ratio                 |