

Installation instructions for B1825 Medium Duty 2-Piston calipers

Before you begin installation: Strange Engineering calipers are designed for **DRAG RACING ONLY!** Read these instructions thoroughly and save for future reference. If after reading these installation instructions, you have any questions or comments, please do not hesitate to call us.

KIT CONTENTS

Item#	Part#	Qty.	Description
1	B2560C	4	5/16"-18x1.5" Caliper body bolt
2	B1260M	4	5/16" washer
3	P2365F	2	Bleeder assembly
4	P2316	2	1/8" NPT x #3 AN fitting
5	B2560D	2	1/4"-20x 2" Caliper bridge bolt
6	B1260E	4	1/4" washer
7	B2560E	2	Caliper bridge bolt tube
8	B2560A	2	Two piston caliper (outer half)
9	B2560B	2	Two piston caliper (inner half)
10	B5000S	4	Stainless caliper piston
11	B5000T	4	.125" Square o-ring
12	B2510	4	Soft metallic 2-piston caliper pads
13	B1301J	4	3/8" x 1/16 Washers
14	B1301H	16	3/8" x .025" thick caliper shims
15	B5000Y	4	3/8"-24x1 1/8" Caliper mounting bolt

Torque Specifications

Item #	Torque (ft-lbs)
1	20-25
Bleeder	5
3, 4	20-25
5	10
15	35

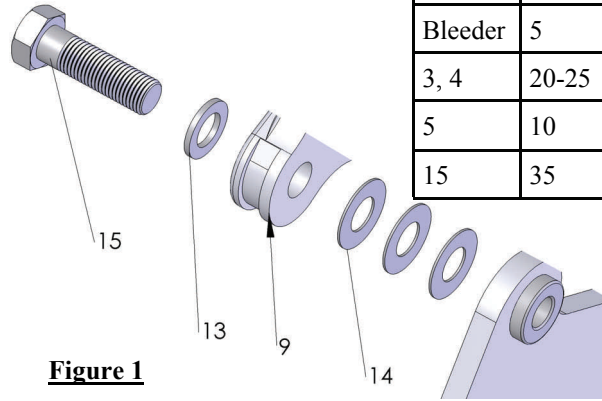

Figure 1

1.) Using one 3/8" washer (13) under the head of each 3/8" bolt (15), mount the calipers onto the caliper mounting bracket. Use .025" shims (14) to center the caliper over the rotor. The bolt (15) should be fully engaged into the press nut. If the bolt is over-engaged, used any remaining shims under the head of the bolt to prevent the bolt from running into the rotor. Press nuts and caliper should always be on opposite sides of the caliper mount. (Fig. 1).

2.) Remove caliper bridge bolt (5) and bridge bolt tube (7). Insert brake pads (12) and reinstall caliper bridge bolt and tube. Torque caliper mounting bolt to 35 ft-lbs. Then torque caliper bridge bolt to 10 ft-lbs.

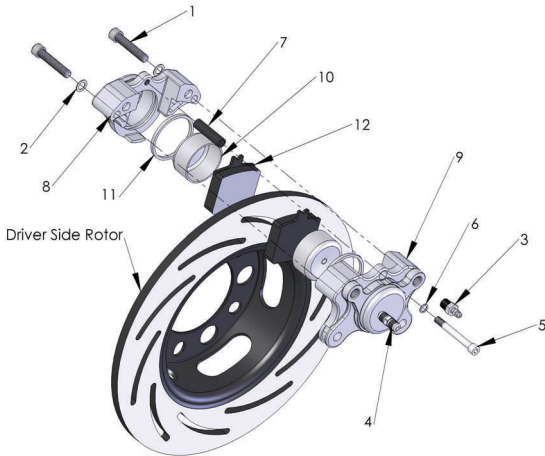

Figure 2

throughout the length of the wheel travel. Additionally, make sure that the brake lines are not interfering with the wheel travel or subject to biting or kinking. Operate the vehicle in a cautious manner until you determine that the brakes are functioning properly. Periodically check the and re-torque all bolts.

3.) The bottom inlet on the inboard half of the caliper is tapped for a 1/8"-27 NPT x #3AN fitting. Install your brake line on this fitting. In the top inlet, install the bleeder assembly. Bleed calipers beginning with the bleeder at the highest point on the inboard half of the caliper. Ensure that there is no air in the system. Use DOT 4 or 5.1 brake fluid ONLY.

4.) A proper break in procedure is required to avoid brake fade and uneven rotor deposits from the pads. It consists of 8-10 brake applications increasing in harshness while allowing the brakes to cool slightly in between; do not keep the brakes applied between stops. After the last stop the brakes should be allowed to cool completely.

5.) After initial installation of this caliper kit, ensure that there is adequate clearance between all braking and chassis components by turning the wheels all the way to the left and right and moving them all the way up and down

WARNING – RACING IS HAZARDOUS · STRANGE BRAKES ARE FOR LEGAL DRAG RACING ONLY

Disclaimer of Warranty – Purchasers using Strange Engineering racing components and equipment any and all inventory services, purchasers acknowledge that due to differing conditions and circumstances under which all equipment and parts are installed and used, purchasers are not relying on Strange Engineering Co. skill or judgment to select or furnish the proper part or equipment. Purchasers expressly affirm they are relying upon their own skill or judgment to select and purchase suitable goods.

Strange Engineering Co. makes no warranties whatsoever, expressed or implied, oral or written, to purchasers. There is no warranty of merchantability made to purchasers. Strange Engineering Co., further excludes any implied warranty of fitness with respect to racing and equipment, any and all inventory and service.