

Driveshaft Speed Sensor Kits

Feature and Benefits

- High resolution 40 tooth trigger wheel
- Requires 4.5-26 VDC supply voltage
- Proven reliability in top fuel cars
- High precision zero speed hall effect sensor
- 0-15kHz operating frequency
- Made in USA
- Industry standard 3/8-24 Fully threaded sensor body
- Terminated with Deutsch DTM plug
- Stainless steel housing - more durable than aluminum bodies
- Includes mating Deutsch DTM receptacle & pins

FORD 9" SENSOR KIT

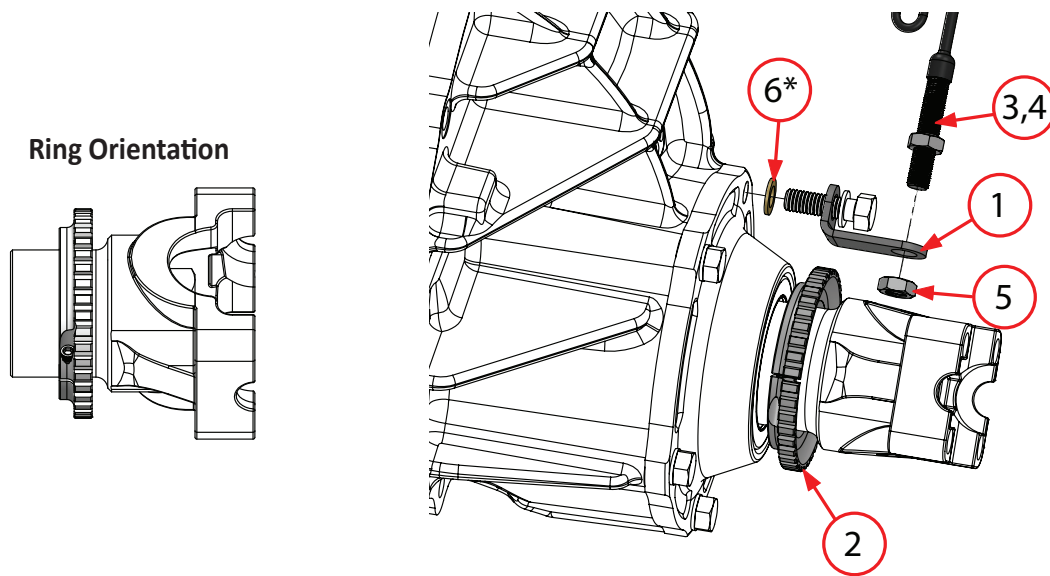

Assembly instructions

1. Remove one pinion support bolt.
2. Align the sensor hole on the bracket (1) with the pinion center line. Use the same pinion bolt to secure the bracket. (**For Ford 9" small stem applications**, a washer (6*) is needed between the bracket and pinion support to space the sensor ring further away from the seal.)
3. Use the two jam nuts (5) to secure the sensor (3/4)
4. Install the two halves of the trigger wheel (2) onto the yoke, ensuring it lines up with the sensor bracket hole. Apply blue loctite and Hand tighten the bolts to lock it in place.
5. Then adjust the sensor air gap approximately 0.030" away from the trigger wheel. Tighten jam nuts 3 ft-lbs.

KITS AVAILABLE		
PART#	DESCRIPTION	PINION SUPPORT
U1613-T	Ford 9" Small Stem	N1914, N1917, N1920, N1922
U1614-T	Ford 9" Large Stem	N1921 / N1922
U1613-THD	HD Pro Small Stem	N2300D / N2300DB
U1614-THD	HD Pro Large Stem	N2300D / N2300DB

PARTS LIST			
ITEM#	PART#	QTY	DESCRIPTION
1a	N1927S	1	Ford 9" Sensor Bracket
1b	N2300S	1	Pro HD Sensor Bracket
2	U1513/14	1	2-Piece Trigger ring
3	B4200A	1	Hall effect sensor w/jam nut
4	B4200B	1	Deutch DTM Receptacle
5	P2335	1	3/8-24 Jam nut
6*	S3402N	1	3/8 Washer (Only U1613-T)

ULTRA CASE SENSOR KIT

MANUFACTURING DATE RESTRICTION

Can only be used with **N1950A /N1953A** Pinion supports manufactured after 6/23 and **N1950AD** after 12/23 which have 3/8 sensor holes with a locking set screw hole

PART#	A
N1950A	0.825"
N1953A	0.700"
N1950AD	0.675"

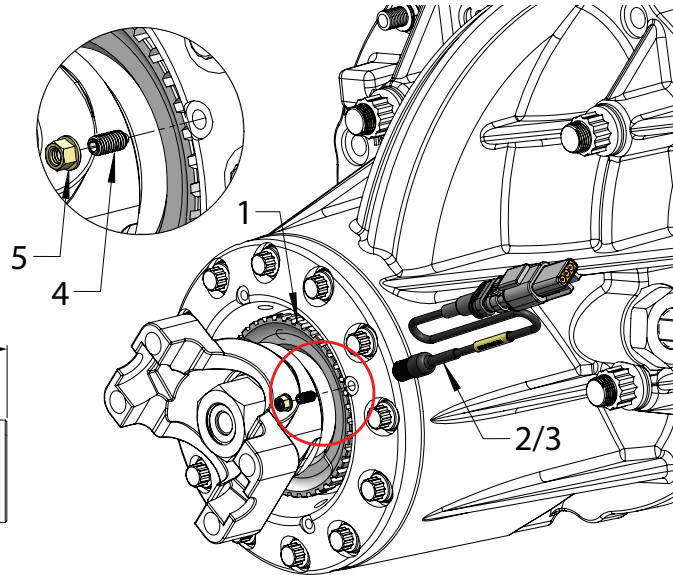
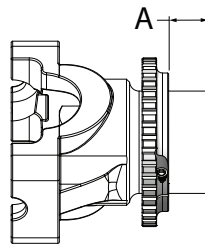

Assembly instructions

1. Remove the yoke and Install the two halves of the trigger wheel (1) onto the yoke, measure "A" from the end of the yoke (**Note the image provided for orientation**). Apply blue loctite and Hand tighten the bolts to lock it in place.
 - Applications using U1613-TUC will need to swap seals to avoid sensor ring interference. Pinion will have to be removed to press out existing seal.
2. The pinion support will have 2 sets of sensor holes one 5/16 and the other 3/8. Using a 3/8 hole, thread the sensor (2) in with approximately 0.030" air gap from the trigger wheel.
3. Fix the sensor in place using the Set screw (4) and lock it down with the jet nut (5) to prevent it from vibrating out of place.

KITS AVAILABLE		
PART#	DESCRIPTION	PINION SUPPORT
U1613-TUC	Ultra Small Stem Taper/Taper & Taper/Ball	N1950A / N1950AD N1953A
U1614-TUC	Ultra Large Stem Taper/Taper & Taper/Ball	N1950A / N1950AD N1953A

PARTS LIST			
ITEM#	PART#	QTY	DESCRIPTION
1	U1513/14	1	2-Piece Trigger ring
2	B4200A	1	Hall effect sensor w/jam nut
3	B4200B	1	Deutch DTM Receptacle
4	N1952S	1	10-32 x 3/8 Nylon tip set screw
5	Q1000G	1	10-32 Jet nut
6	N1960L	1	Seal (U1613-TUC only)

LIGHTENED ULTRA CASE SENSOR KIT

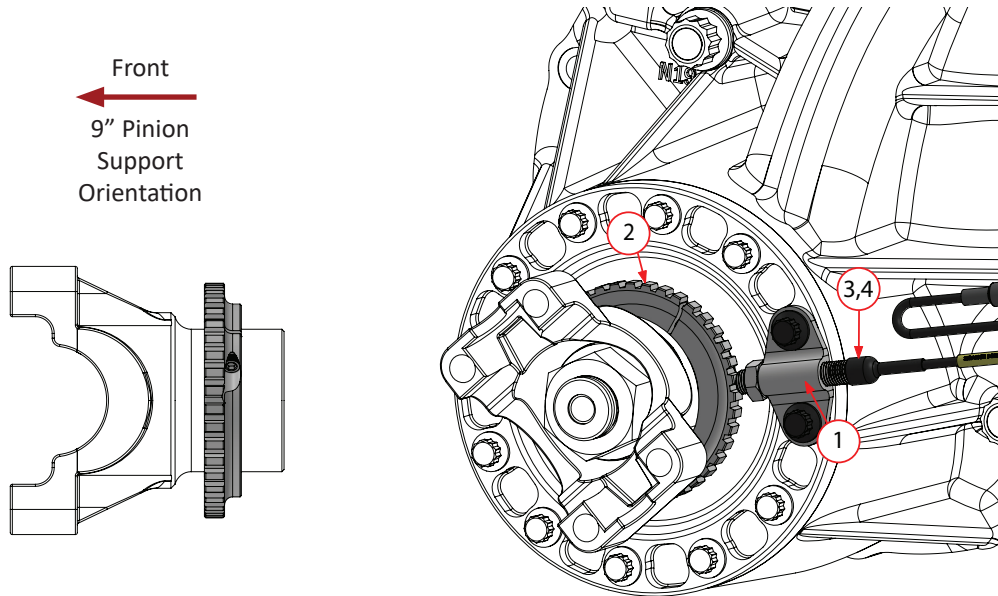

Assembly instructions

1. Remove 2 pinion support bolts.
2. Place the bracket (1) onto the pinion support, use the removed bolts to secure it in place
3. Install the two halves of the trigger wheel (2) onto the yoke, ensuring it lines up with the sensor bracket hole. Apply blue loctite and Hand tighten the bolts to lock it in place.
4. Thread the sensor (3) in place, leaving an air gap of approximately 0.030" from the trigger ring and set it with the nut (torque to 3 ft-lbs) provided with the sensor as shown.

KITS AVAILABLE		
PART#	DESCRIPTION	PINION SUPPORT
U1613-TUCB	Ultra Case Small Stem Taper/Ball	N1952A
U1614-TUCB	Ultra Case Large Stem Taper/Ball	N1952A

PARTS LIST			
ITEM#	PART#	QTY	DESCRIPTION
1	N1952U	1	3/8-24 Sensor Bracket
2	U1513/14	1	2 Piece Trigger ring
3	B4200A	1	Hall effect sensor
4	B4200B	1	Deutch DTM Receptacle

BILLET CASE SENSOR KIT

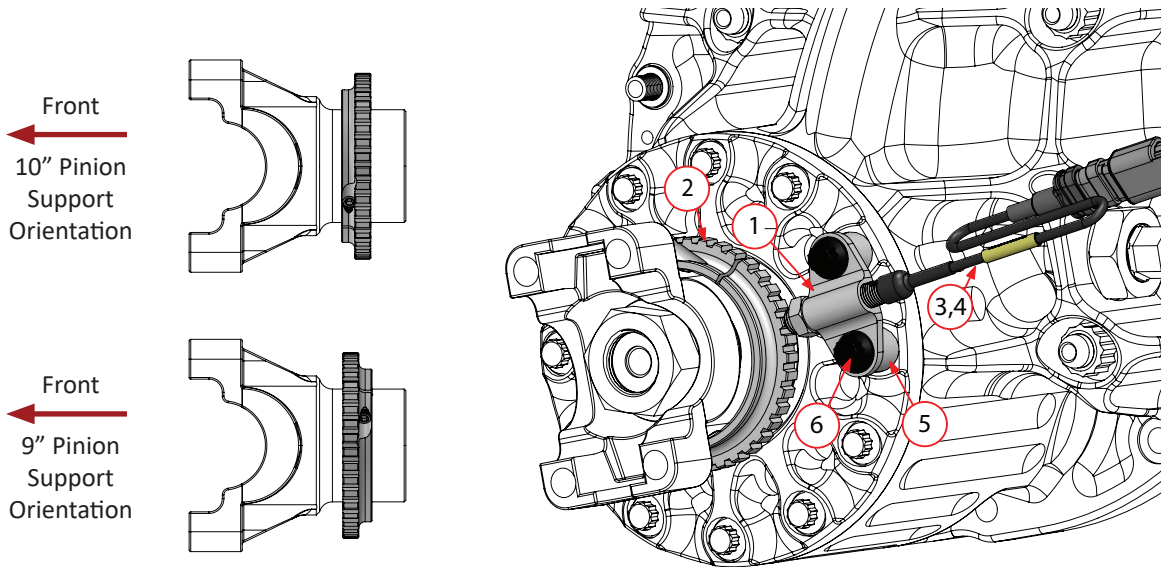

Assembly instructions

1. Remove two pinion support bolts.
2. Insert provided spacers (5) in their place.
3. Use long pinion support bolts (6) and washer (7) to secure the sensor bracket (1) onto the spacers.
4. Install the two halves of the trigger wheel (2) onto the yoke, lining up the ring with the sensor hole. Apply blue loctite and Hand tighten the bolts to lock it in place
5. Thread the sensor (3) in place, with approximately 0.030" air gap from the trigger ring and set it with the nut (torque to 3 ft-lbs) installed on the sensor as shown.

KITS AVAILABLE		
PART#	DESCRIPTION	PINION SUPPORT
U1613-TB	Billet Small Stem	N1950AB / N1950AC / N1950AE N1950AF
U1614-TB	Billet Large Stem	N1950AB / N1950AC / N1950AE N1950AF

PARTS LIST			
ITEM#	PART#	QTY	DESCRIPTION
1	N1952U	1	3/8-24 Sensor Bracket
2	U1513/14	1	2 Piece Trigger ring
3	B4200A	1	Hall effect sensor
4	B4200B	1	Deutch DTM Receptacle
5	N1952SB	2	Sensor Bracket spacer
6	N1950CS	2	3/8-16 x 1.75" 12pt bolt
7	N1950CW	2	Pinion support washer

DANA 60/8.8/ 12 BOLT SENSOR KIT

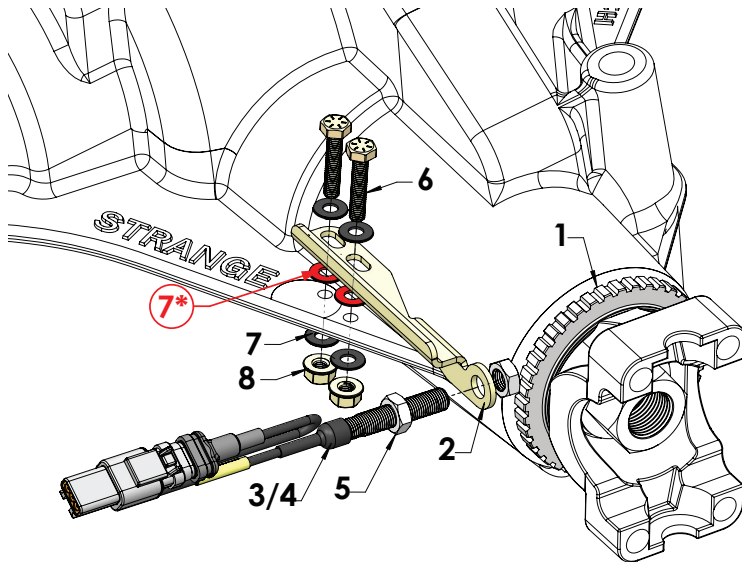

*See note in the instructions

KITS AVAILABLE	
PART#	DESCRIPTION
U1617-T	12 Bolt/Dana 60/8.8

PARTS LIST			
ITEM#	PART#	QTY	DESCRIPTION
1	U1517	1	U1601/U1599/U1596 Trigger ring
2	U1517SB	1	Sensor Bracket
3	B4200A	1	Hall effect sensor w/jam nut
4	B4200B	1	Deutch DTM Receptacle
5	P2365	2	3/8-24 Jam nut
6	U1517B	2	1/4-28 x 1-1/4" HHCS
7*	B5080D	8	1/4" Washer
8	S3430G	2	1/4-28 Locknut

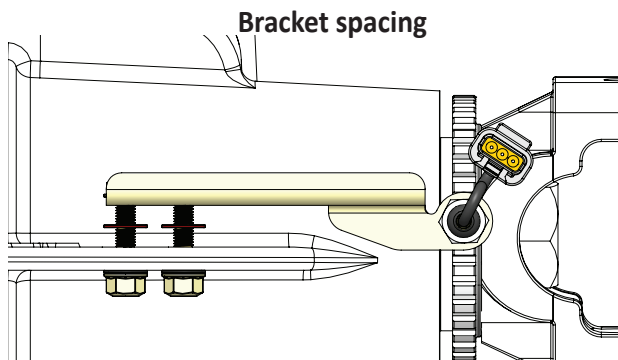

Ring Orientation/Information

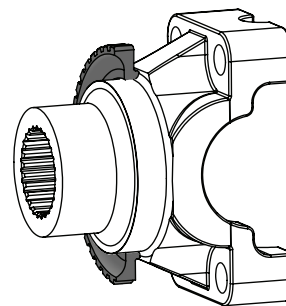

- Yokes dated 04/15 or later will have a $\varnothing 2.500''$ machined surface for a trigger wheel
- Will not fit Strange nodular yoke
- Will not fit OEM or other manufacturer's yoke

Assembly & modifications instructions

1. Remove Yoke, ensure the radius on the trigger wheel faces the radius on the yoke and press the ring flush against the yoke. Re-install the yoke.
2. Place the sensor bracket on the rib. Align the sensor hole onto the trigger wheel.
3. Ensure the bracket is parallel and mark the holes on the bracket onto the rib.
4. Grind away obstructions and drill two 17/64" holes 3/4" apart.
5. Secure the bracket in place using the bolts, nuts and washer provided.

Note: If the center hole of the sensor bracket does not line up with the center of the trigger wheel, washers can be used to properly line up the bracket.
6. Align the sensor with the trigger wheel and secure it with the nuts (5) leaving approximately 0.030" of air gap between them. Torque jam nut to 3 ft-lbs.

U1513 & U1514 TRIGGER WHEEL ASSEMBLY

TRIGGER WHEEL KIT CONTENTS			
ITEM#	PART#	QTY	DESCRIPTION
1a	U1513A/B	1	U1603 Trigger ring
1b	U1514A/B	1	U1604 Trigger ring
2	U1514C	2	8-32 x 3/4" SHCS *Apply blue loctite

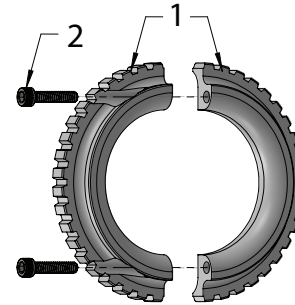

B4200A Sensor Connector Plug Pin Layout

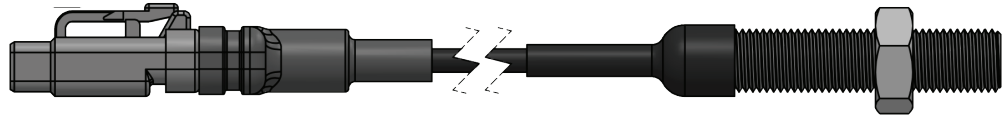
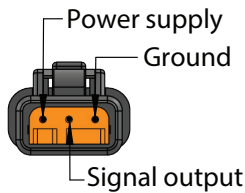

DTM Receptacle Assembly & Information

B4200B DTM CONNECTOR KIT CONTENTS			
ITEM#	PART#	QTY	DESCRIPTION
-	DTM04-3P	1	3 position receptor
-	WM-3P	1	Receptacle wedge lock
-	1060-20-0222	3	Connector pin accepts 16-22 AWG wire

STEP 1: Crimping Connectors



- Crimp the connector pins, using an open barrel crimper for an even press.

STEP 2: Inserting connector pin

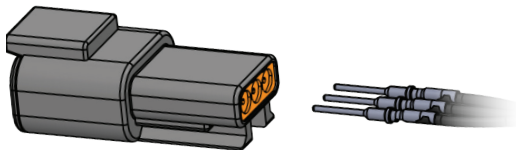

- Insert the crimped connectors through the grommet in the receptor and ensure that they snap into place. Lightly tugging the wires to confirm they are secure.

STEP 3: Securing connectors with a wedge lock

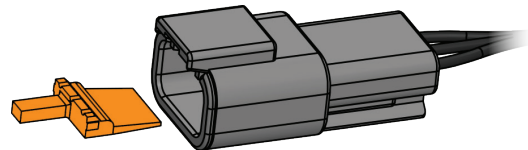

- Place the wedge lock into the opposite side, securing the pins and wires into place.
Note: Use needle nose pliers to remove the wedge.

WARNING - RACING IS HAZARDOUS · STRANGE BRAKES ARE FOR LEGAL DRAG RACING ONLY

Disclaimer of Warranty - Purchasers using Strange Engineering racing components and equipment any and all inventory services, purchasers acknowledge that due to differing conditions and circumstances under which all equipment and parts are installed and used, purchasers are not relying on Strange Engineering Co. skill or judgment to select or furnish the proper part or equipment. Purchasers expressly affirm they are relying upon their own skill or judgment to select and purchase suitable goods.

Strange Engineering Co. makes no warranties whatsoever, expressed or implied, oral or written, to purchasers. There is no warranty of merchantability made to purchasers. Strange Engineering Co., further excludes any implied warranty of fitness with respect to racing and equipment, any and all inventory and service.