

MEDIUM DUTY FRONT BRAKE KIT INSTALLATION INSTRUCTIONS

KIT #
B4479WC

APPLICATIONS
'98 - '02 Camaro & Firebird
using stock hubs

Important Notes

Strange Engineering brake kits are designed for DRAG RACING ONLY

Brake fittings do not come pre-installed, it will need a layer of Teflon sealer applied to the thread (Figure# 1 for torque specs)

Semi-metallic brake pads (B2510) have 0.200" minimal thickness

11.25" Steel brake rotors (B2792 & B2793) have 0.312" minimal thickness

KIT CONTENTS			
ITEM#	PART#	QTY	DESCRIPTION
1a	B2793	1	Left hand Rotor
1b	B2792	1	Right hand rotor
2	B4178C	2	Register Ring
3	B4182E	4	M12 X1.75 X 50mm FHS
4	B4479A	2	Caliper Mount
5	B1301E	4	3/8-24 press nut
6	B4152F	4	M12 X 1.75 Nylock nut
7	B1301H	16	3/8" I.D. x 0.025" Thick Caliper Shim
8	B2510	4	2-piston Caliper Pad
9	B2560	2	2- piston Caliper
10	B1301J	4	3/8" I.D. x 1/16" Thick Flat Washer
11	B5000Y	4	3/8"-24 x 1.125" Caliper Bolt
12	P2316	2	1/8" NPT x -3AN Fitting

1. Raise and support front of vehicle on a level surface using suitable equipment.
2. Remove wheel, caliper, rotor and brake line. Inspect all ball joints for excessive play and replace as needed.
3. Install the caliper mount (4) using M12 bolt (3) and nut (6) making sure the press nuts (5) are facing towards the rotor (8). Torque to 50 ft.-lbs.
4. Place the register ring (2) on the hub then slide the rotor (1) over the wheel studs flush to the face.
- **Please read B1825 instructions for complete caliper instructions.**
5. Attach caliper (9) using 3/8"-24 caliper bolts (11) with red loctite and 3/8" I.D. washers (10). Use 3/8" I.D. caliper shims (7) to center the caliper over the rotor, making sure pads contact the rotor evenly. The caliper bolt (11) should be fully engaged into the press nut. If the bolt is over engaged, use any remaining shims under

the head of the bolt to prevent it from running into the rotor. Torque the caliper mounting bolts (11) to 35 ft.-lbs.

Note: Because all knuckles vary slightly you may not need the same amount of shim on both sides of the vehicle.

6. Connect the brake lines to the calipers. Calipers are tapped to 1/8"-27 NPT and supplied with -3AN fittings. Use proper adapters to connect them to existing lines or use new -3AN braided steel line (teflon lined). Bleed the calipers with DOT 4 or DOT 5.1 brake fluid ONLY.
7. Mount the wheel and tire assembly on the hub and torque the lug nuts.
8. A proper break in procedure is required to avoid brake fade and uneven rotor deposits from the pads. It consists of 8-10 brake applications increasing in harshness while allowing the brakes to cool slightly in between; do not keep the brakes applied between stops. After the last stop the brakes should be allowed to cool completely.

FIGURE 1:
B4479WC Driver Side Camaro

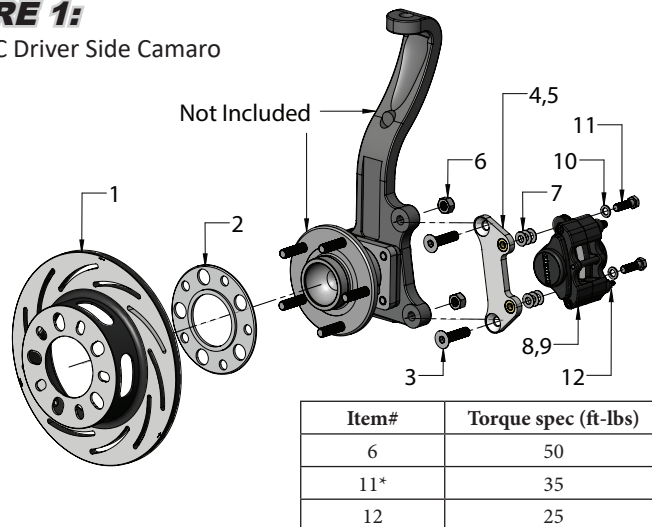

*Must apply red loctite

Read these instructions thoroughly and save for future reference.

If after reading these installation instructions, you have any questions or comments, please do not hesitate to call us.