



Strange



EVOLUTION 4-PISTON FRONT BRAKE KIT INSTRUCTIONS

KIT

B4142WCE - 4.75" B.C wheels
B4143WCE - 4.50" B.C wheels

APPLICATIONS

1982-1986 Mustang
1987-1993 Mustang with
4 cylinder spindles
1982-1986 Thunderbird
1987-1988 Thunderbird with
6 & 8 cylinder spindles
1981-1988 Cougar

Evolution Rotors

- Dynamic Drive Mount (DDM) system secures the rotor and allows for rotor thermal expansion
- DDM system design is secured by an internal Spirolox, eliminating heavy bolts and hardware
- Unique Aero Slot design reduces rotating weight and promotes even heat dissipation

Before you begin installation:

- Strange Engineering brake kits are designed for DRAG RACING ONLY!
- Read these instructions thoroughly and save for future reference.
- Brake fittings do not come pre-installed, it will need a layer of Teflon sealer applied to the thread (Figure# 2 for torque specs)
- If after reading these installation instructions, you have any questions or comments, please do not hesitate to call us.

KIT CONTENTS

ITEM#	PART#	QTY	DESCRIPTION
1	A1028A	10	1/2"-20 x 2.5" Wheel stud
2	A1028B	10	1/2" I.D. Wheel stud washer
3	B1301E	4	3/8"-24 Press nut (Installed in B4180A)
4	B1330A	2	Inner hub bearing cup (Timken L68110 installed in B1332A/B4158FM)
5	B1330B	2	Inner hub bearing cone (Timken L68149)
6	B1332A	2	Front hub "SF" 4.75" B.C. (For B4142WC)
-	B4154SPM	2	Front hub "HS" - 4.50" B.C. (For B4143WC)
7	B1330C	2	Outer hub bearing cup (Timken LM12710 installed in B1332A/B4158FM)
8	B1330D	2	Outer hub bearing cone (Timken LM12749)
9	B1381D	4	3/8"-16 x 1" caliper bracket bolt
10	B2798AS	2	Evolution S Rotor
11	B2794B	2	2-Piece rotor adapter
12	B2794D	2	Spirolock
13	B1301H	16	3/8" I.D. x 0.025" Thick caliper shim
14	B1301J	4	3/8" I.D. x 1/16" Thick flat washer
15	B5000Y	4	3/8"-24 x 1.125" Caliper bolt
16	B5010	4	Soft Metallic 4-piston caliper pad
17	B1900	1	Billet Caliper
18	P2316	2	1/8" NPT x -3AN Fitting
19	B4154E	2	Aluminum hub cap
20	B4142A	2	Caliper mounting bracket
21	S3402N	4	3/8" AN Washer
22	S3520F	2	#222 Buna O-ring (Installed on B4154E)
23	B1328B	2	Hub seal (National 6815)
24	B4170B	2	1/8" Front Wheel Spacer

WARNING - RACING IS HAZARDOUS · STRANGE BRAKES ARE FOR LEGAL DRAG RACING ONLY

Disclaimer of Warranty - Purchasers using Strange Engineering racing components and equipment any and all inventory services, purchasers acknowledge that due to differing conditions and circumstances under which all equipment and parts are installed and used, purchasers are not relying on Strange Engineering Co. skill or judgment to select or furnish the proper part or equipment. Purchasers expressly affirm they are relying upon their own skill or judgment to select and purchase suitable goods. Strange Engineering Co. makes no warranties whatsoever, expressed or implied, oral or written, to purchasers. There is no warranty of merchantability made to purchasers. Strange Engineering Co., further excludes any implied warranty of fitness with respect to racing and equipment, any and all inventory and service.

Installation instructions

Figure # 2

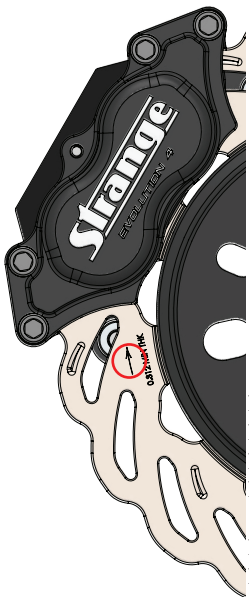

1. Raise and support front of vehicle on a level surface using suitable equipment.
2. Remove wheel, caliper, rotor, hub, and brake line. Inspect all ball joints for excessive play and replace as needed.
3. Cut off the lower mounting ear on the spindle at a distance approximately 1" from the center of the bottom caliper mounting hole as shown in Figure#3.
4. Drill holes to 5/16" and tap the caliper mounting bracket holes on the spindle to 3/8"-16 (see Figure#3).
5. Install the caliper mounting bracket (20) using the 3/8" caliper bracket bolts (9) and 3/8"AN washers (21) making sure that the press nuts (3) are facing towards the rotor (10,11). Torque to 35 ft.-lbs.
6. Install 1/2" Dia. wheel studs (1) in front hub (6) using 1/2" I.D. wheel stud washer (2) and a small amount of BLUE Loc-tite®. Torque all studs to 65 ft.-lbs. Note:Consult your wheel and/or lug nut manufacturer for proper lug nut torque.
7. Pack inner (5) and outer bearing cones (8) with a suitable wheel bearing grease. Note: A bearing packer is recommended for this procedure; If one is not available work as much grease as possible into the cage and around the rollers.
8. Wipe a thin layer of wheel bearing grease onto the bearing surface of the inner and outer cups (4, 7) and place the inner bearing cone (5) into the front hub (6).
9. Press the hub seal (23) into the inboard side of the hub (6) flush to the outer face of the hub.
10. Slide the hub assembly onto the spindle then slide the outer bearing cone (8) into the hub (6).
11. Install the key washer and spindle nut.
12. Mount the wheel and tire assembly on the hub and snug the lug nuts.
13. While rotating the wheel, torque the spindle nut to approximately 20 ft.-lbs. Then, loosen the spindle nut until the wheel spins freely and there is no end play.
14. Install the stamped spindle nut retainer, cotter pin, aluminum hub cap (19), and remove the wheel and tire.
15. Slide the rotor (10, 11, 12) over the wheel studs flush to the face of the hub (6). Note: Slotted rotors mount with the arrow pointing in the direction of normal rotation (See Figure #3).
- Please read B1950 instructions for complete caliper instructions.
16. Attach caliper (16, 17) with the arrow facing in the direction of normal rotor rotation using 3/8"-24 caliper bolts (14) with red loc-tite and 3/8" I.D. washers (13). Use 3/8" I.D. caliper shims (12) to center the caliper over the rotor, making sure pads contact the rotor evenly. The caliper bolt (14) should be fully engaged into the press nut. If the bolt is over engaged, use any remaining shims under the head of the bolt to prevent it from running into the rotor. Torque the caliper mounting bolts (14) to 35 ft.-lbs. Note: Because all spindles vary slightly you may not need the same amount of shim on both sides of the vehicle.
17. Connect the brake lines to the calipers. Calipers are tapped to 1/8"-27 NPT and supplied with -3AN fittings. Use proper adapters to connect them to existing lines or use new -3AN braided steel line (teflon lined). Bleed the calipers with DOT 4 or DOT 5.1 brake fluid ONLY.
18. A proper break in procedure is required to avoid brake fade and uneven rotor deposits from the pads. It consists of 8-10 brake applications increasing in harshness while allowing the brakes to cool slightly in between; do not keep the brakes applied between stops. After the last stop the brakes should be allowed to cool completely.

FIGURE # 2: Exploded B4142WCE / B4143WCE Assembly View

FIGURE # 3: Adjustment guidelines

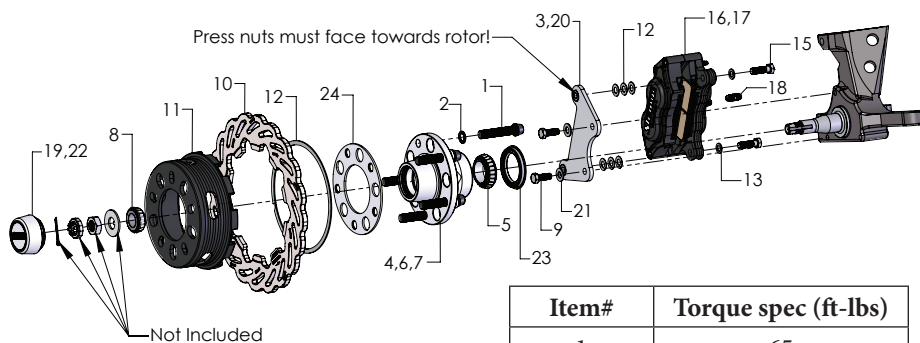

Item#	Torque spec (ft.-lbs)
1	65
9	35
15	35
18	25

*Must apply red loctite

